



TABLES AND SINKS

SERVING THE FOOD INDUSTRY SINCE 1951

10" X 14" X 10" THREE TUB SINK - 3.5" CENTER DRAIN AND 2 DRAIN BOARDS

Item: 43756



HIGH QUALITY

18-Gauge Stainless Steel
3 Tub Sink With 16-Gauge
Galvanized Legs



LIMITED
WARRANTY



Authorized Dealer

TABLES AND SINKS

10" X 14" X 10" THREE TUB SINK



TECHNICAL DRAWING WITH DIMENSIONS

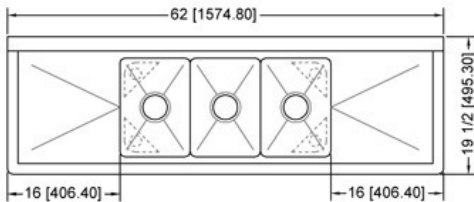

Center Drain

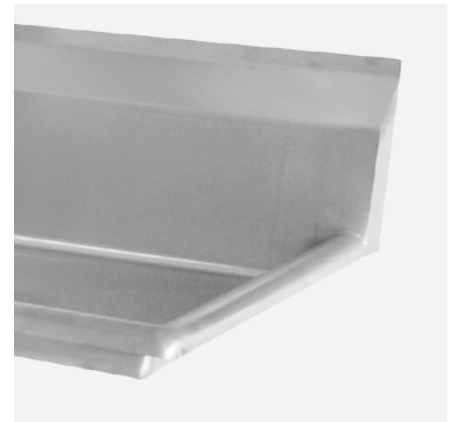

Raised Edges

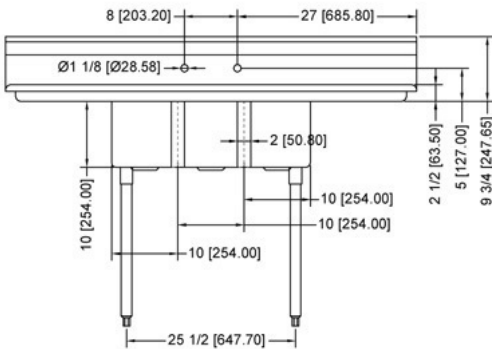

16-Gauge Galvanized Legs

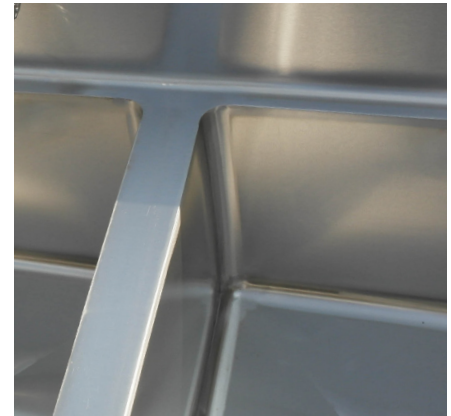

Rounded corner

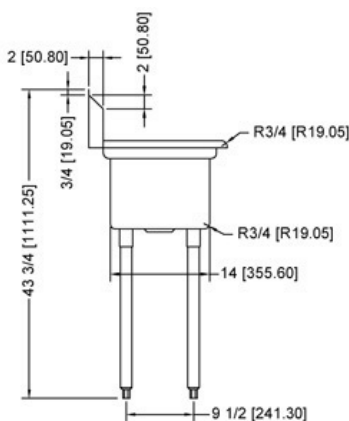

TECHNICAL SPECIFICATIONS

ITEM NUMBER	43756
DESCRIPTION	Three Tub Sink with 2 drain boards and center drain
SINK SIZE	10" x 14" x 10" / 254 x 355.6 x 254 mm
DRAIN SIZE	3.5" / 89 mm
OVERALL DIMENSIONS (WDH)	62" x 19.5" x 43.75" / 1574.8 x 495 x 1111.3 mm
WEIGHT	43.12 lbs / 19.6 kgs



OMCAN INC.

Telephone: 1-800-465-0234
 Fax: (905) 607-0234
 Email: sales@omcan.com
 Website: www.omcan.com



Follow us to keep up to date with the latest news and offers

