



FOOD EQUIPMENT

SERVING THE FOOD INDUSTRY SINCE 1951

32-INCH DISPLAY WARMER

Item: 43465

Model: DW-CN-0085



Always promise your customers warm, fresh goods with this Omcan 85L capacity display warmer. This sleek, attractive display warmer is constructed with a stainless steel exterior, making this a durable and easy-to-clean unit. Use this warmer for concession stands, convenience stores, cafes, and small delis. This display warmer can complement any commercial establishment.



WARRANTY
PARTS AND LABOR



Authorized Dealer

Technical Drawing With Dimensions:

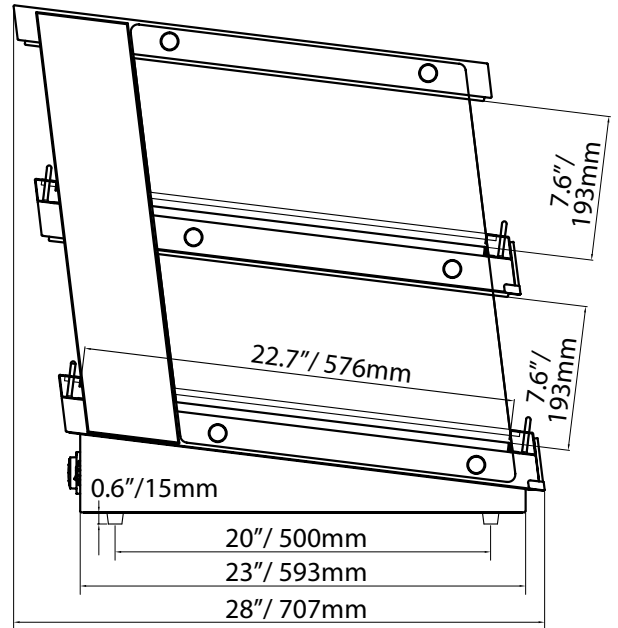
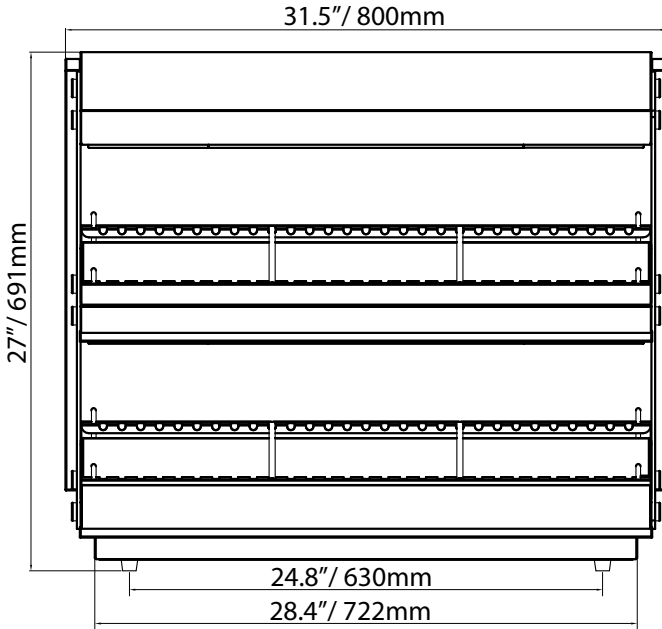

Features:

- Stainless steel exterior
- Tempered glass sides
- Independent heat and light controls for each shelf
- Adjustable thermostat
- Adjustable divider rods for easy organization of food product
- Fixed rubber feet

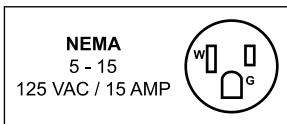

TECHNICAL SPECIFICATION

ITEM NUMBER	43465
MODEL	DW-CN-0085
CAPACITY	85 L / 3 Cu.ft
TEMPERATURE RANGE	30 - 85°C / 86 - 185°F
POWER	1160w
RATED CURRENT	10A
ELECTRICAL	110V/60Hz
NET DIMENSIONS	31.5" x 27.8" x 27.2" / 800 x 707 x 691 mm
GROSS DIMENSIONS	34.1" x 30.2" x 27.8" / 866 x 767 x 736mm
NET WEIGHT	41 kg / 90.4 lbs
GROSS WEIGHT	44 kg / 97 lbs

OMCAN INC.

Telephone: 1-800-465-0234

Fax: (905) 607-0234

Email: sales@omcan.com

Website: www.omcan.com



Follow us to keep up to date with the latest news and offers

