



*SERVING THE FOOD INDUSTRY SINCE 1951*

## 47-INCH DISPLAY WARMER WITH 186 L CAPACITY

Item: 44438 Model: DW-CN-0186

**SELF-SERVE DISPLAY WARMER  
PERFECT FOR KEEPING YOUR FOOD  
HOT, FRESH, AND READY TO GO**

- Brilliant Internal LED illumination on top
- Adjustable temperature controller
- Adjustable chrome plated shelves
- Sliding doors



**WARRANTY**  
PARTS AND LABOR



NEMA  
5 - 15  
125 VAC / 15 AMP



Authorized Dealer

# FOOD EQUIPMENT

47-INCH DISPLAY WARMER WITH 186 L CAPACITY

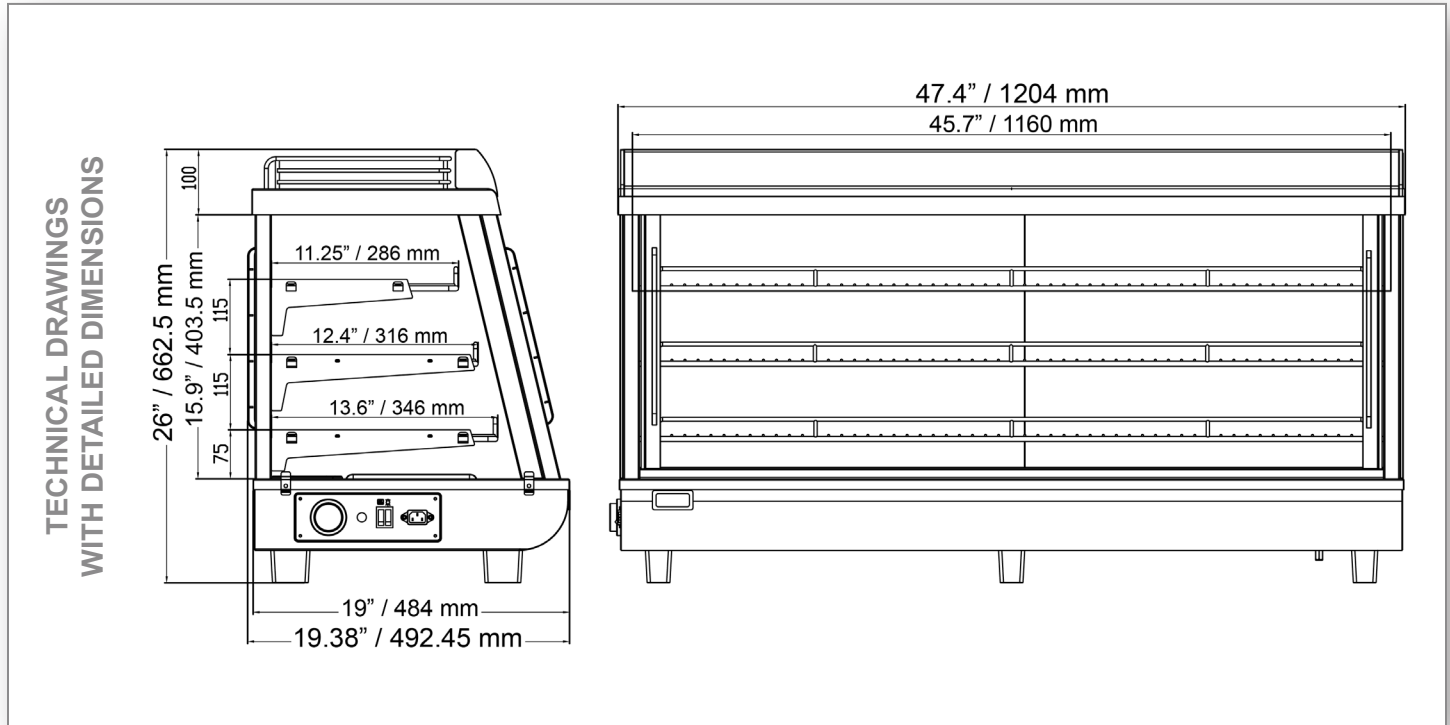

## TECHNICAL SPECIFICATIONS

ITEM NUMBER	44438
MODEL	DW-CN-0186
TEMPERATURE RANGE	30°C - 90°C / 86°F - 194°F
STORAGE VOLUME	186 L / 6.6 cu. ft.
POWER (W)	1800 W
LAMP POWER	1.44 x 3 W
SHELF DIMENSIONS	TOP: 45.68" x 11.29" / 1160.5 x 287 mm MIDDLE: 45.68" x 12.4" / 1160.5 x 316 mm BOTTOM: 45.68" x 13.64" / 1160.5 x 346.5 mm
SHELF LOAD CAPACITY	22 lbs. / 10 kg.
ELECTRICAL	110V / 60Hz / 1Ph
DIMENSIONS (DWH)	19.38" x 47.4" x 26" / 492.45 x 1204 x 662.5 mm
GROSS DIMENSIONS	21.69" x 50.3" x 27.36" / 551 x 1278 x 695 mm
NET WEIGHT	117.9 lbs. / 53.5 kg.
GROSS WEIGHT	123.45 lbs. / 56 kg.

## OMCAN INC.

Telephone: 1-800-465-0234

Fax: (905) 607-0234

Email: sales@omcan.com

Website: www.omcan.com



Follow us to keep up to date with the latest news and offers

