

INSURICE[§] SINGLE PF-i2000² FILTRATION SYSTEM

DELIVERS PREMIUM QUALITY WATER FOR ICE APPLICATIONS

Insurice Single PF-i2000² System: EV9324-21
i2000² Replacement Cartridge: EV9612-22
EC210 Prefilter Cartridge: EV9534-26



APPLICATIONS

- ◆ Ice Machines
 - Cubers 750 lbs./day
 - Flakers 1,500 lbs./day

FEATURES • BENEFITS

- ◆ Reduces water-related ice machine problems caused by scale buildup from dirt and dissolved minerals*
 - ◆ Sanitary cartridge replacement is simple, quick and clean. Internal filter parts are never exposed to handling or contamination
 - ◆ Reduces maintenance and service costs by reducing scale* and clogging of distribution lines, evaporator plate and pump
 - ◆ Exclusive precoat filtration provides superior chlorine taste and odor reduction and micro-filters dirt and particles as small as 0.5 micron in size by mechanical means
 - ◆ Proprietary Pentair[§] Everpure[§] Micro-Pure[§] II filtration media effectively inhibits the growth of bacteria on the filter media that can decrease product life
 - ◆ Reduces chlorine taste & odor and other offensive contaminants
 - ◆ 20" prefilter reduces dirt and particles
 - ◆ NSF/ANSI Standard 53 certified to reduce cysts such as *Cryptosporidium* and *Giardia* by mechanical means
- *As tested by Pentair

INSTALLATION TIPS

- ◆ Choose a mounting location suitable to support the full weight of the system when operating.
- ◆ Never use saddle valve for connection.
- ◆ Use 3/4" water line.
- ◆ Do not connect system to water-cooled condenser.
- ◆ Install vertically with cartridges hanging down and allow 2½" (6.35 cm) clearance below the cartridge for easy cartridge replacement.
- ◆ Flush cartridges by running water through system for five minutes at full flow.

OPERATION TIPS

- ◆ Change cartridges on a regular six (6) month preventative maintenance program.
- ◆ Change cartridges when capacity is reached or when pressure falls below 10 psi (0.7 bar).
- ◆ Service flow rate must not exceed 1.67 gpm (6.3 Lpm).
- ◆ Always flush the filter cartridge at time of installation and cartridge change.
- ◆ Inspect Pentair Everpure EC210 cartridge periodically to determine dirt load.
- ◆ Replace EC210 cartridge when dirt has penetrated through to the inner core of the cartridge.

SIZING

- ◆ Service Flow Rate:
Maximum 1.67 gpm (6.3 Lpm)
- ◆ Capacity:
9,000 gallons (34,069 L)

INSURICE SINGLE PF-i2000² FILTRATION SYSTEM

EV9324-21

Insurice Single PF-i2000² System: EV9324-21
i2000² Replacement Cartridge: EV9612-22
EC210 Prefilter Cartridge: EV9534-26

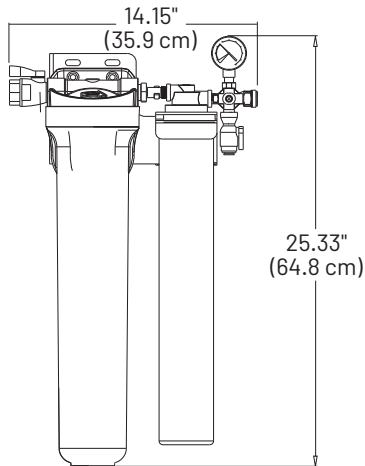

SPECIFICATIONS

- ◆ **Service Flow Rate**
Maximum 1.67 gpm (6.3 Lpm)
- ◆ **Rated Capacity**
9,000 gallons (34,069 L)
- ◆ **Pressure Requirements**
10 – 125 psi (0.7 – 8.6 bar), non-shock
- ◆ **Temperature**
35 – 100°F (2 – 38°C)
- ◆ **Overall Dimensions**
25.33" L x 14.5" W x 6.47" D
(64.8 x 35.9 x 16.4 cm)
- ◆ **Inlet Connection**
Inlet Connection: 3/4"
- ◆ **Outlet Connection**
Outlet Connection: 3/8"
- ◆ **Operating Weight**
19 lbs (8.6 kgs)
- ◆ **Shipping Weight**
10 lbs (4.5 kgs)
- ◆ **Electrical Connection**
None required



System Tested and Certified by NSF International against NSF/ ANSI Standards 42 and 53 for the reduction of:	
STANDARD NO. 42 – AESTHETIC EFFECTS	STANDARD NO. 53 – HEALTH EFFECTS
Chemical Reduction Taste & Odor Chlorine	Mechanical Filtration Cyst
Mechanical Filtration Nominal Particulate Class I	

EPA Est. No. 002623-IL-002

WARRANTY

Everpure water treatment systems by Pentair (excluding replaceable elements) are covered by a limited warranty against defects in material and workmanship for a period of five years after date of purchase. Everpure replaceable elements (filter cartridges and water treatment cartridges) are covered by a limited warranty against defects in material and workmanship for a period of one year after date of purchase. See printed warranty for details. Pentair will provide a copy of the warranty upon request.

The contaminants or other substances removed or reduced by this drinking water system are not necessarily in your water. Do not use with water that is microbiologically unsafe or of unknown quality without adequate disinfection before or after the system. Systems certified for cyst reduction may be used with disinfected water that may contain filterable cysts.

Since the conditions under which our products may be used are beyond our control, we cannot accept any liability with respect to the improper installation, application and/or use of our products.



World Headquarters
1040 Muirfield Drive
Hanover Park, IL 60133
United States
800.942.1153 (US Only)
630.307.3000 Main
cseverpure@pentair.com

Australia
1-21 Monash Drive
Dandenong South, Vic 3175
Australia
011.1300 576 190 Tel
au.everpure@pentair.com

China
21F Cloud 9 Plaza, NO 1118
Shanghai, 200052
China
86.21.3211.4588 Tel
china.water@pentair.com

India
Boulevard, B-9/A,
7th Floor - Tower B Sector 62
Noida - 201301
91.120.419.9444 Tel
indiacustomer@pentair.com

Europe
Pentair Water Belgium BVBA
Industriepark Wolfstee,
Toekomstlaan 30,
B-2200 Herentals
Belgium
+32.(0).14.283.504 Tel
sales@everpure-europe.com

Japan Inc.
Hashimoto MN Bldg. 7F,
3-25-1 Hashimoto, Midori-ku,
Sagamihara-shi
Kanagawa 252-0143
Japan
81.(0)42.775.3011 Tel
info@everpure.co.jp

Southeast Asia
390 Havelock Road,
#04-01 King's Centre
Singapore 169662
65.6768.5800 Tel
cseverpure@pentair.com

§ Pentair trademarks and logos are owned by Pentair plc or its affiliates. For a detailed list of where Pentair trademarks are registered, please visit www.pentair.com/en/registrations.html. Third party registered and unregistered trademarks and logos are the property of their respective owners. Because we are continuously improving our products and services, Pentair reserves the right to change specifications without prior notice. Pentair is an equal opportunity employer.

EV9324-21 SE19 ©2019 Pentair Filtration Solutions, LLC. All Rights Reserved.