



EVERPURE® HIGH FLOW CSR TRIPLE-MC² SYSTEM WITH LPA

DELIVERS PREMIUM QUALITY WATER FOR COMBINATION APPLICATIONS

High Flow CSR Triple-MC² System with LPA:
EV9328-05
MC² Replacement Cartridge: EV9612-56
EC210 Prefilter Cartridge: EV9534-26
SS-IMF Cartridge: EV9799-32



APPLICATIONS

Combination of Coffee Brewers, Espresso Machines, Hot Chocolate Dispensers, Fountain and Ice Machines

Multiple Equipment and Combinations

FEATURES • BENEFITS

One system provides premium quality water to fountain, coffee and ice machines

Sanitary cartridge replacement is simple, quick and clean; internal filter parts are never exposed to handling or contamination

Proprietary Micro-Pure® II filtration media effectively inhibits the growth of bacteria on the filter media that can decrease product life

Exclusive precoat filtration provides superior chlorine taste & odor reduction and micro-filters dirt and particles as small as 0.2* micron in size by mechanical means

SR-X with SS-IMF Cartridge inhibits scale buildup in ice machines and coffee brewers

Low pressure alarm signals to notify when cartridges need changing

20" prefilter captures larger dirt particles

NSF/ANSI Standard 53 certified to reduce cysts such as *Cryptosporidium* and *Giardia* by mechanical means

* Validated by ISO 17025 accredited lab for 99.999% reduction of *Pseudomonas diminuta* following the ASTM F838-05 protocol for the validation of 0.2 µm sterilizing grade filters.

INSTALLATION TIPS

Choose a mounting location suitable to support the full weight of the system when operating.

Use 3/4" water line.

Fountain equipment connections are made to the outlet part of the system before the SR-X System.

Coffee brewer and ice machine connections are made after the SR-X Feeder; a tee is required.

Install vertically with cartridges hanging down and allow 2 1/2" (6.35 cm) clearance below the cartridge for easy cartridge replacement.

Flush cartridges by running water through flushing valve for five (5) minutes at full flow.

OPERATION TIPS

Change cartridges on a regular six (6) month preventative maintenance program.

Change cartridges when capacity is reached or when pressure falls below 10 psi (0.7 bar).

Change SS-IMF Cartridge before Hydroblend™ compound is completely used up.

Change prefilter cartridge when excessively dirty.

Always flush the filter cartridge at time of installation and cartridge change.

SIZING

Rated Capacity: 27,000 gallons (102,206 L)

Service Flow Rate: Maximum 5 gpm (18.9 Lpm)

EVERPURE® HIGH FLOW CSR TRIPLE-MC² SYSTEM WITH LPA EV9328-05

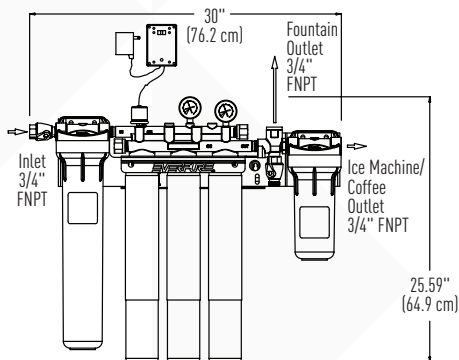

SPECIFICATIONS

Service Flow Rate
Maximum 5 gpm (18.9 Lpm)

Rated Capacity
27,000 gallons (102,206 L)

Pressure Requirements
10–125 psi (0.7–8.6 bar), non-shock

Temperature
35–100°F (2–38°C)

Overall Dimensions
25.59" L x 30" W x 6.75" D
(64.9 cm x 76.2 cm x 17.1 cm)

Inlet Connection
3/4"

Outlet Connection
3/4"

Shipping Weight
39 lbs (17.6 kgs)

Operating Weight
49 lbs (22.2 kgs)

Electrical Connection
110 V electrical connection required for
Low Pressure Alarm



System Tested and Certified by NSF International against NSF/ANSI Standards 42 and 53 for the reduction of:

STANDARD NO. 42 –
AESTHETIC EFFECTS

Chemical Reduction
Taste & Odor
Chlorine

Mechanical Filtration
Nominal Particulate Class I

STANDARD NO. 53 –
HEALTH EFFECTS

Mechanical Filtration
Cyst

EPA Est. No. 002623-IL-002

The contaminants or other substances removed or reduced by this drinking water system are not necessarily in your water. Do not use with water that is microbiologically unsafe or of unknown quality without adequate disinfection before or after the system. Systems certified for cyst reduction may be used with disinfected water that may contain filterable cysts.

Since the conditions under which our products may be used are beyond our control, we cannot accept any liability with respect to the improper installation, application and/or use of our products.



WATER QUALITY SYSTEMS

EVERPURE-SHURFLO WORLD HEADQUARTERS, 1040 MUIRFIELD DRIVE, HANOVER PARK, IL 60133 USA • FOODSERVICE.PENTAIR.COM
800.942.1153 (US ONLY) • 630.307.3000 MAIN • 630.307.3030 FAX • CSEVERPURE@PENTAIR.COM EMAIL

EVERPURE-SHURFLO AUSTRALIA, 1-21 MONASH DRIVE, DANDENONG SOUTH, VIC 3175 AUSTRALIA
011.1300 576 190 TEL • 011.61.39.562.7237 FAX • AU.EVERPURE@PENTAIR.COM EMAIL

EVERPURE-SHURFLO CHINA, 21F CLOUD 9 PLAZA, NO 1118, SHANGHAI, 200052, CHINA
86.21.3211.4588 TEL • 86.21.3211.4580 FAX • CHINA.WATER@PENTAIR.COM EMAIL

EVERPURE-SHURFLO INDIA, GREEN BOULEVARD, B-9/A, 7TH FLOOR - TOWER B SECTOR 62, NOIDA - 201301
91.120.419.9444 TEL • 91.120.419.9400 FAX • INDIACUSTOMER@PENTAIR.COM EMAIL

EVERPURE-SHURFLO EUROPE, PENTAIR WATER BELGIUM BVBA, INDUSTRIEPARK WOLFSTEE, TOEKOMSTLAAN 30, B-2200 HERENTALS, BELGIUM
+32.(0).14.283.504 TEL • +32.(0).14.283.505 FAX • SALES@EVERPURE-EUROPE.COM EMAIL

EVERPURE-SHURFLO JAPAN INC., HASHIMOTO MN BLDG. 7F, 3-25-1 HASHIMOTO, MIDORI-KU, SAGAMIHARA-SHI KANAGAWA 252-0143, JAPAN
81.(0)42.775.3011 TEL • 81.(0)42.775.3015 FAX • INFO@EVERPURE.CO.JP EMAIL

EVERPURE-SHURFLO SOUTHEAST ASIA, 390 HAVELOCK ROAD, #04-01 KING'S CENTRE, SINGAPORE 169662
65.6768.5800 TEL • 65.6737.5149 FAX • CSEVERPURE@PENTAIR.COM EMAIL

All Pentair trademarks and logos are owned by Pentair, Inc. or its affiliates. All other registered and unregistered trademarks and logos are the property of their respective owners. Because we are continuously improving our products and services, Pentair reserves the right to change specifications without prior notice. Pentair is an equal opportunity employer.

WARRANTY

Everpure water treatment systems by Pentair® (excluding replaceable elements) are covered by a limited warranty against defects in material and workmanship for a period of five years after date of purchase. Everpure replaceable elements (filter cartridges and water treatment cartridges) are covered by a limited warranty against defects in material and workmanship for a period of one year after date of purchase. See printed warranty for details. Pentair will provide a copy of the warranty upon request.