

HIGH FLOW CSR TRIPLE-MC² SYSTEM

DELIVERS PREMIUM QUALITY WATER FOR COMBINATION APPLICATIONS

High Flow CSR Triple-MC² System: EV9328-06
MC² Replacement Cartridge: EV9612-56
EC210 Prefilter Cartridge: EV9534-26
SS-IMF Cartridge: EV9799-32



APPLICATIONS

- ◆ Combination of Coffee Brewers, Espresso Machines, Hot Chocolate Dispensers, Fountain and Ice Machines
- ◆ Multiple Equipment and Combinations

FEATURES • BENEFITS

- ◆ One system provides premium quality water to high flow fountain dispensers, coffee makers and ice machines
- ◆ Sanitary cartridge replacement is simple, quick and clean; internal filter parts are never exposed to handling or contamination
- ◆ Proprietary Pentair[®] Everpure[®] Micro-Pure[®] II filtration media effectively inhibits the growth of bacteria on the filter media that can decrease product life
- ◆ Exclusive precoat filtration provides superior chlorine taste & odor reduction and micro-filters dirt and particles as small as 0.2* micron in size by mechanical means
- ◆ Reduces chlorine taste & odor and other offensive contaminants that can adversely affect the taste of beverages
- ◆ Increases the overall efficiency of equipment
- ◆ 20" prefilter captures larger dirt particles
- ◆ Pentair Everpure SR-X with Pentair Everpure SS-IMF Cartridge inhibits scale buildup in ice machines and coffee brewers
- ◆ NSF/ANSI Standard 53 certified to reduce cysts such as *Cryptosporidium* and *Giardia* by mechanical means

INSTALLATION TIPS

- ◆ Choose a mounting location suitable to support the full weight of the system when operating.
- ◆ Use 3/4" water line.
- ◆ Fountain equipment connections are made to the outlet part of the system before the SR-X System.
- ◆ Coffee brewer and ice machine connections are made after the SR-X Feeder; a tee is required.
- ◆ Install vertically with cartridges hanging down and allow 2 1/2" (6.35 cm) clearance below the cartridge for easy cartridge replacement.
- ◆ Flush cartridges by running water through flushing valve for five (5) minutes at full flow.

OPERATION TIPS

- ◆ Change cartridges on a regular six (6) month preventative maintenance program.
- ◆ Change cartridges when capacity is reached or when pressure falls below 10 psi (0.7 bar).
- ◆ Change SS-IMF Cartridge before Hydroblend™ compound is completely used up.
- ◆ Change prefilter cartridge when excessively dirty.
- ◆ Always flush the filter cartridge at time of installation and cartridge change.

SIZING

- ◆ Service Flow Rate:
Maximum 5 gpm (18.9 Lpm)
- ◆ Capacity:
27,000 gallons (102,206 L)

*Validated by ISO 17025 accredited lab for 99.999% reduction of *Pseudomonas diminuta* following the ASTM F838-05 protocol for the validation of 0.2 μm sterilizing grade filters.

HIGH FLOW CSR TRIPLE-MC² SYSTEM

EV9328-06

High Flow CSR Triple-MC² System: EV9328-06
MC² Replacement Cartridge: EV9612-56
EC210 Prefilter Cartridge: EV9534-26
SS-IMF Cartridge: EV9799-32

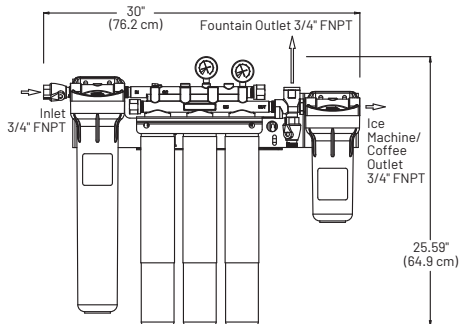

SPECIFICATIONS

- ◆ **Service Flow Rate**
Maximum 5 gpm (18.9 Lpm)
- ◆ **Rated Capacity**
27,000 gallons (102,206 L)
- ◆ **Pressure Requirements**
10 – 125 psi (0.7 – 8.6 bar), non-shock
- ◆ **Temperature**
35 – 100°F (2 – 38°C)
- ◆ **Overall Dimensions**
25.59" L x 30" W x 6.74" D
(64.9 cm x 76.2 cm x 17.1 cm)
- ◆ **Inlet Connection** 3/4"
- ◆ **Outlet Connection** 3/4"
- ◆ **Operating Weight**
49 lbs (22.2 kgs)
- ◆ **Shipping Weight**
39 lbs (17.6 kgs)
- ◆ **Electrical Connection**
None required



| | |
|--|-------------------------------------|
| System Tested and Certified by NSF International against NSF/ ANSI Standards 42 and 53 for the reduction of: | |
| STANDARD NO. 42 – AESTHETIC EFFECTS | STANDARD NO. 53 – HEALTH EFFECTS |
| Chemical Reduction Taste & Odor Chlorine | Mechanical Filtration Cyst |
| Mechanical Filtration Nominal Particulate Class I | |

EPA Est. No. 002623-IL-002

WARRANTY

Everpure water treatment systems by Pentair (excluding replaceable elements) are covered by a limited warranty against defects in material and workmanship for a period of five years after date of purchase. Everpure replaceable elements (filter cartridges and water treatment cartridges) are covered by a limited warranty against defects in material and workmanship for a period of one year after date of purchase. See printed warranty for details. Pentair will provide a copy of the warranty upon request.

The contaminants or other substances removed or reduced by this drinking water system are not necessarily in your water. Do not use with water that is microbiologically unsafe or of unknown quality without adequate disinfection before or after the system. Systems certified for cyst reduction may be used with disinfected water that may contain filterable cysts.

Since the conditions under which our products may be used are beyond our control, we cannot accept any liability with respect to the improper installation, application and/or use of our products.



World Headquarters
1040 Muirfield Drive
Hanover Park, IL 60133
United States
800.942.1153 (US Only)
630.307.3000 Main
cseverpure@pentair.com

Australia
1-21 Monash Drive
Dandenong South, Vic 3175
Australia
011.1300 576 190 Tel
au.everpure@pentair.com

China
21F Cloud 9 Plaza, NO 1118
Shanghai, 200052
China
86.21.3211.4588 Tel
china.water@pentair.com

India
Boulevard, B-9/A,
7th Floor - Tower B Sector 62
Noida - 201301
91.120.419.9444 Tel
indiacustomer@pentair.com

Europe
Pentair Water Belgium BVBA
Industriepark Wolfstee,
Toekomstlaan 30,
B-2200 Herentals
Belgium
+32.(0).14.283.504 Tel
sales@everpure-europe.com

Japan Inc.
Hashimoto MN Bldg. 7F,
3-25-1 Hashimoto, Midori-ku,
Sagamihara-shi
Kanagawa 252-0143
Japan
81.(0)42.775.3011 Tel
info@everpure.co.jp

Southeast Asia
390 Havelock Road,
#04-01 King's Centre
Singapore 169662
65.6768.5800 Tel
cseverpure@pentair.com

§ Pentair trademarks and logos are owned by Pentair plc or its affiliates. For a detailed list of where Pentair trademarks are registered, please visit www.pentair.com/en/registrations.html. Third party registered and unregistered trademarks and logos are the property of their respective owners. Because we are continuously improving our products and services, Pentair reserves the right to change specifications without prior notice. Pentair is an equal opportunity employer.

EV9328-06 SE19 ©2019 Pentair Filtration Solutions, LLC. All Rights Reserved.