



REFRIGERATION

SERVING THE FOOD INDUSTRY SINCE 1951

49-INCH GLASS DOOR FREEZERS WITH 2 DOORS

Item: 50031 Model: FR-CN-1250-HC



Product might not be exactly as shown

HIGH PERFORMANCE AND QUALITY COMMERCIAL FREEZER

This model features self closing glass doors and high density polyurethane insulation.

Features:

- Outside material: Painted steel
- LED lighting
- Self-closing doors
- Removable door gasket
- Plastic coated steel shelves with shelf tag holder
- Automatic defrosting
- Removable installation board for easy maintenance
- Polyurethane insulation

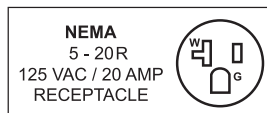

Authorized Dealer

REFRIGERATION

49-INCH GLASS DOOR FREEZERS WITH 2 DOORS



TECHNICAL DRAWING / DIMENSIONS

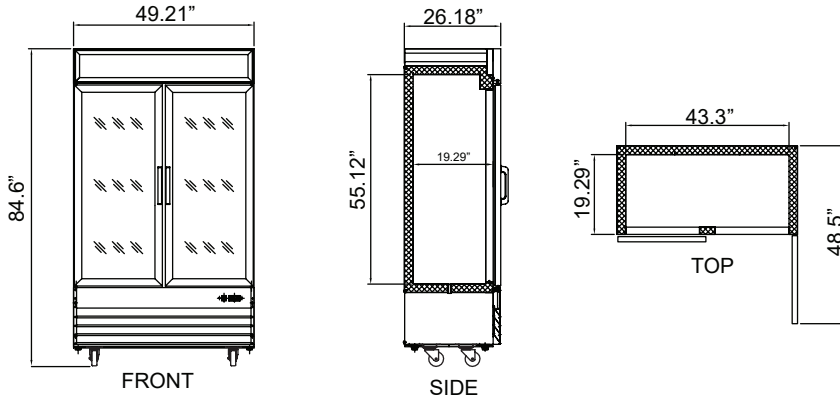

TECHNICAL SPECIFICATION

ITEM NUMBER	50031
MODEL	FR-CN-1250-HC
DESCRIPTION	2-Door Glass Freezer with "D" type breaker
TEMPERATURE RANGE	-23C - -18°C / -10°F - 0°F
MAX AMBIENT TEMP. RATING	32°C / 90°F
POWER	0.75 HP
ELECTRICAL	110V/60Hz/1Ph
AMPS	9.4
REFRIGERANT	R290
COOLING SYSTEM	Ventilated
NUMBER OF DOORS	2
NUMBER OF SHELVES	8
NET VOLUME	29 cu.ft. / 830 liters
SHELF CAPACITY	90 lbs. / 41 kg.
EXTERIOR DIMENSIONS (WDH)	49.21" x 26.18" x 84.6" / 1250 x 665 x 2148.84 mm
INTERIOR DIMENSIONS (WDH)	43.3" x 19.29" x 55.12" / 1100 x 490 x 1400 mm
PACKAGING DIMENSIONS	52.16" x 30.31" x 87" / 1325 x 770 x 2210 mm
NET WEIGHT	397 lbs. / 180 kg.
GROSS WEIGHT	452 lbs. / 205 kg.



OMCAN INC.

Telephone: 1-800-465-0234

Fax: (905) 607-0234

Email: sales@omcan.com

Website: www.omcan.com



Follow us to keep up to date with the latest news and offers



2017E&OE