



# BEVERAGE-AIR

Project: _____	AIA#
Item: _____	
Location: _____	SIS#
Approved: _____	

## GF BAR EQUIPMENT

### GF48L Glass and Plate Froster

**MODEL:**  
**GF48L-B**  
**GF48L-S**



**GF48L-B**



**GF48L-S**

**3 Year Parts/Labor Warranty**  
**Additional 2 Year Compressor Warranty**

### CABINET CONSTRUCTION

- Exterior is available in wear resistant vinyl on steel in black Finish or stainless steel finish
- Standard interior construction utilizes galvanized steel
- Top includes easy glide, stainless steel lids and stainless steel counter top with edge
- Full electronic control
- Four (4) shelves and (2) two bottom racks standard
- Two (2) shelf ledges standard with three (3) mounting points
- Chills glasses and plates at -10°F
- Flexibility in design provides for plate storage and chilling
- Automatic defrost of coil is standard
- Built-in condensate evaporator system
- No floor drain or additional plumbing is needed

### OPTIONS & ACCESSORIES

- Stainless steel interior
- Locks
- 3" - 6" Casters
- 6" Adjustable legs with plate
- Horizontal mount thermometer
- Dial thermometer
- Remote option

### REFRIGERATION SYSTEM

- Refrigeration system uses R404A refrigerant to comply with all environmental concerns
- Automatic, electric defrost
- Epoxy coated evaporator coil

GF48L Bar Equipment: Glass and Plate Froster Series



3779 Champion Blvd., Winston-Salem, NC 27105  
 1-888-845-9800 Fax: 1-336-245-6453  
 Beverage-Air.com sales@bevair.com



# BEVERAGE-AIR

## Bar Equipment - Glass Frosters

Models: GF48L-B, GF48L-S

MODEL	GF48L-B	GF48L-S
<b>EXTERNAL DIMENSIONAL DATA</b>		
Width Overall	48"	48"
Depth Overall	26 1/8"	26 1/8"
Height Overall	33 5/8"	33 5/8"
Number of Lids	2	2
<b>INTERNAL DIMENSIONAL DATA</b>		
NET Capacity (cubic ft.)	8.13	8.13
Internal Width Overall (in)	44"	44"
Internal Depth Overall (in)	22"	22"
Internal Depth Useable (in)	17 1/2"	17 1/2"
Internal Height Overall (in)	18 1/4"	18 1/4"
Number of Dividers	4	4
Number of 12 oz. Mugs	164	164
Number of 8" Plates	250	250
<b>ELECTRICAL DATA</b>		
Full Load Amperes 115/60/1	7.5	7.5
<b>REFRIGERATION DATA</b>		
Horsepower	1/2	1/2
Capacity (BTU/Hr)*	1132	1131
<b>WEIGHT DATA</b>		
Gross Weight (Crated lbs)	292 lbs	292 lbs
Height - Crated	39"	39"
Width - Crated	51 1/2"	51 1/2"
Depth - Crated	29"	29"

### Model Views

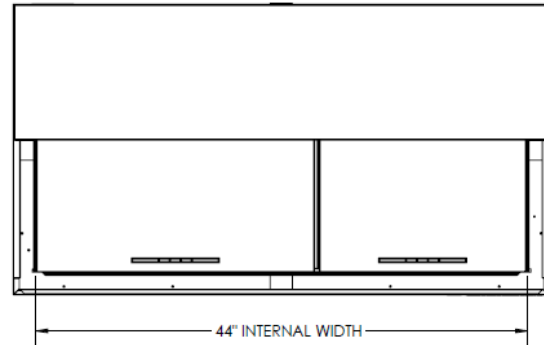

### Plan View

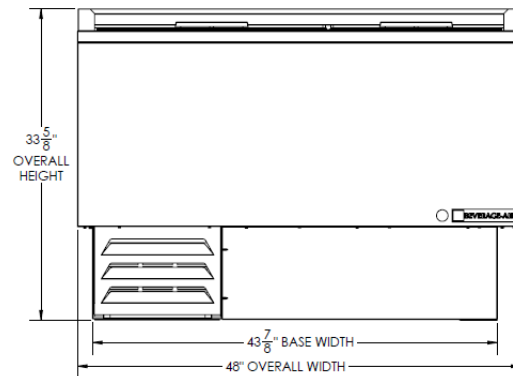

### Elevation View

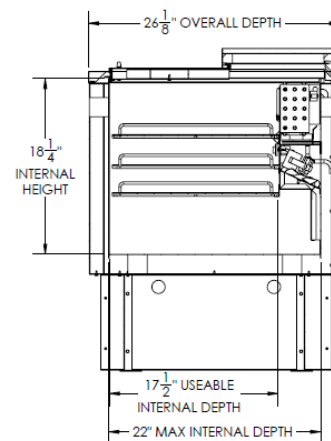

### Side View

### ELECTRICAL CONNECTION



115/60/1  
NEMA-5-15P

Units pre-wired at factory and include 8' long cord and plug set.



an Ali Group Company



The Spirit of Excellence

3779 Champion Blvd., Winston-Salem, NC 27105  
1-888-845-9800 Fax: 1-336-245-6453  
Beverage-Air.com sales@bevair.com