



# CONVECTION OVEN

## MARATHONER GOLD - HALF SIZE

### GAS, SINGLE DECK



GH/10SC shown with optional legs/casters

- GH/10SC
- GH/10TC

**Standard Features**

- 30,000 BTU (NAT or LP)
- Available standard depth
- Single deck convection oven is 33" in height (with 4" legs)
- Patented "plug-in, plug-out" control panel
- Stainless steel front, sides and top
- Single door with window (Full 180° opening)
- 11-position rack guides and 5 plated oven racks
- Electronic ignition with solid state temperature controls
- Forced cool down fan mode
- Oven "heat" light cycles with burners
- (1) year limited parts and labor warranty (reference <http://www.southbendnc.com/service.html> for limited warranty details)

**Available Controls**

**SC-Standard Controls**

140°F to 500°F solid state thermostat and 60 minute mechanical cook timer.

**TC-Touchscreen Controls**

150°F to 550°F temperature controller with 140°F to 200°F "Hold" thermostat. Digital display shows time and temperature. A fan cycle timer pulses the fan. Recipes can be created and used in oven group 'Rack' mode to cook multiple items at once on different timers.

**OPTIONS & ACCESSORIES AT ADDITIONAL COST**

- |  |   |  |
|--|---|--|
| <input type="checkbox"/> Stainless steel oven interior         | <input type="checkbox"/> 26" stainless steel legs with flanged legs   | <input type="checkbox"/> Marine edge top   |
| <input type="checkbox"/> Stainless steel soild door            | <input type="checkbox"/> Stainless steel legs with rack pan guide kit | <input type="checkbox"/> Swivel Caster - front with locks  |
| <input type="checkbox"/> 12" stainless steel legs              | <input type="checkbox"/> 26" stainless steel legs                     | <input type="checkbox"/> 3/4" quick disconnect with flexible hose (specify length: 3ft, 4ft, or 5ft) |
| <input type="checkbox"/> 26" stainless steel legs with casters | <input type="checkbox"/> Casters 4" or 6"                             |  |

**STANDARD CONSTRUCTION SPECIFICATIONS**

**Exterior Finish:** Stainless steel front, top, and sides. Back is aluminized steel.

**Door:** Single door with window. Stainless steel construction, heavy-duty welded steel frame and 5/8" diameter hinge pin.

**Oven Interior:** Porcelain enamel finish, coved, fastener free.

**Rack and Rack Guides:** Heavy-duty removable wire rack guides spaced on 1-5/8" centers offer 11 different rack positions. 5 wire racks provided with each oven.

**Blower Fan and Motor:** 1/2hp, 2-speed motor, 1710/1120 r.p.m motor

mounted to the right side.

**Oven Heating:** 30,000 BTU (NAT or LP). Oven heating is regulated by an adjustable, solid state thermostat control. Jet Stream style burners direct flame towards rear of combustion chamber. Combustion products are drawn into oven interior and recirculated prior to venting.

**Electronic Ignition:** Hot surface ignitor with flame safety device.

**Control Panel:** Located on front, at right side of oven, away from heat zone. Removable panel opens downward for easy servicing.

**Legs:** 4" stainless steel legs standard.



Approval Notes: \_\_\_\_\_

\_\_\_\_\_

Dimensions shown in inches and (millimeters)

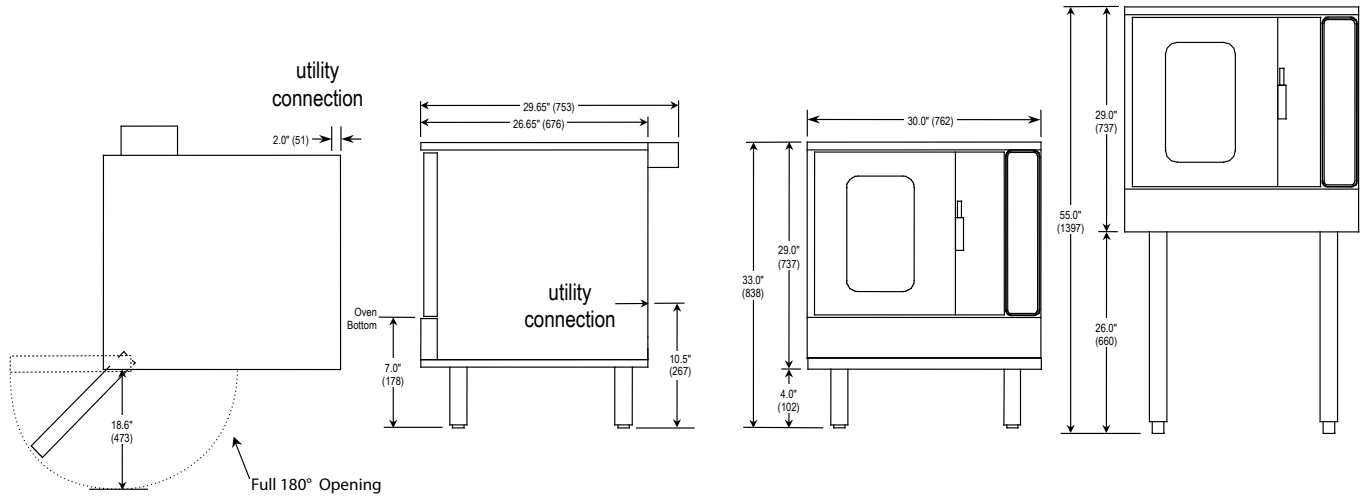

**DIMENSIONS**

MODEL	OVEN INTERIOR			RACK CLEARANCE		SHIPPING CRATE				
	WIDTH	DEPTH	HEIGHT	WIDTH	DEPTH	WIDTH	DEPTH	HEIGHT	VOLUME	WEIGHT
GH/10	15.80" (401)	21.30" (541)	20" (508)	13" (330)	21" (533)	57.50" (1461)	45.5" (1157)	45" (1143)	68.1 cu. ft. (1.93 cu. m.)	420 lbs. (190.5 kg)

**Note:** When shipped on 26" legs, crated height is 79" (2006 mm)

Dimensions shown in inches and (millimeters)

**UTILITY INFORMATION**

- GAS:**
- 30,000 BTU (NAT or LP)
  - One 3/4" male connection
  - Required minimum inlet pressure:
    - Natural gas 7" W.C.
    - Propane gas 11" W.C.

- ELECTRIC:** Standard: 120/60/1 phase, furnished with 6' cord w/3-prong plug (1 plug/deck). NEMA #5-15p. Total maximum amps 7.9.
- Optional: 208/60/1 (190-219 volts). Supply must be wired to junction box with terminal block located at rear. Total maximum amps 4.3 per deck.
- Optional: 240/60/1 (220-240 volts). Supply must be wired to junction box with terminal block located at rear. Total maximum amps 3.8 per deck.
- Optional: 240/50/1 (208-240 volts). Supply must be wired to junction box with terminal block located at rear. Total maximum amps 6.0 per deck.

\* All units shipped single phase.  
Single phase can be easily converted to three phase.

**MISCELLANEOUS**

- If using flex hose connector, the I.D should not be smaller than 3/4" and must comply with ANSI Z 21.69.
- If casters are used with flex hose, a restraining device should be used to eliminate undue strain on the flex hose.
- Clearances from combustibles: Top - 0", bottom - 0", right side - 0" and left side - 2"
- Recommend - install under vented hood
- Check local codes for fire and sanitary regulations
- If the unit is connected directly to the outside flue, an A.G.A

approved down draft diverter must be installed at the flue outlet of the oven

- Oven cannot be operated without fan in operation

**NOTICE:**

Southbend has a policy of continuous product research and improvement. We reserve the right to change specifications and product design without notice. Such revisions do not entitle the buyer to corresponding changes, improvements, additions or replacements for previously purchased equipment.

**INTENDED FOR COMMERCIAL USE ONLY.  
NOT FOR HOUSEHOLD USE.**

