



Item: _____
 Quantity: _____
 Project: _____
 Approval: _____
 Date: _____

Heavy Duty Gas Radiant Char-Broilers w/Adjustable or Non-Adjustable Grates

Models:

- GTBG24-AR24 GTBG36-AR36 GTBG48-AR48 GTBG60-AR60
- GTBG24-NR24 GTBG36-NR36 GTBG48-NR48 GTBG60-NR60 GTBG72-NR72



Model GTBG24-AR24

Standard Features:

- SS front, sides and back
- 4" SS adjustable legs
- 3/4" NPT gas regulator on all 24" to 60" wide models with "T" gas manifold connection for straight through rear or flush-mount gas connections.
- 1" NPT gas regulator for GTBG72-NR72 model only. Has "T" gas manifold connection for straight through or nearly flush-mount gas connections.

- SS front rail; 4" (102mm) deep overall with 3 1/2" (89mm) top work surface
- SS large capacity crumb tray
- Reversible cast iron broiler racks in 3" wide sections with 1/8" and 3/16" brand marks.
- 21-3/16" (538mm) broiling grid depth
- 2-position adjustable broiler grates or fixed-position non-adjustable grates
- One cast iron radiant over a 18,000 BTU stainless steel tube burner for every 6" of broiler width.
- One two position hi/lo valve control for each burner.

Optional Features:

- SS skirt for dais/counter surface mounting. The stainless steel skirt will reduce overall unit height by 1 3/4" (44.45mm).
- SS spatter-guard

- Removable wire holding shelf for spatter guards available for 24" and 36" models
- Broiler grate cleaning tool
- Fajita broiling grate: 9" wide, replaces 3 standard grate sections on the left or right end of the broiler. Limit one per broiler.
- Stainless stand with solid top and holding shelves, and adjustable feet
- Stainless stand with solid top and holding shelves, and casters, (locking front)
- Set of reversible cast iron broiler racks with 4 brand marks per 3" section. Brand 3/16" wide.
- Removable stainless steel attachment condiment rail with universal 1/9 or 1/3 food pan cut outs (pans supplied by others)

Specifications:

Garland gas radiant broilers are available with adjustable or non-adjustable cooking racks, in five nominal imperial widths from 24"(600mm) to 60"(1500mm), and with model GTBG72-NR72 only 72"(1800mm), 13" (330mm) high and 32" (814mm) deep. Reversible cast iron grates in 3" (76mm) wide sections overall cooking area depth 21 3/16" (538 mm). One 18,000 BTU burner with individual valve control per 6" of broiler width. Large stainless steel catch tray, stainless steel front, sides, and back.



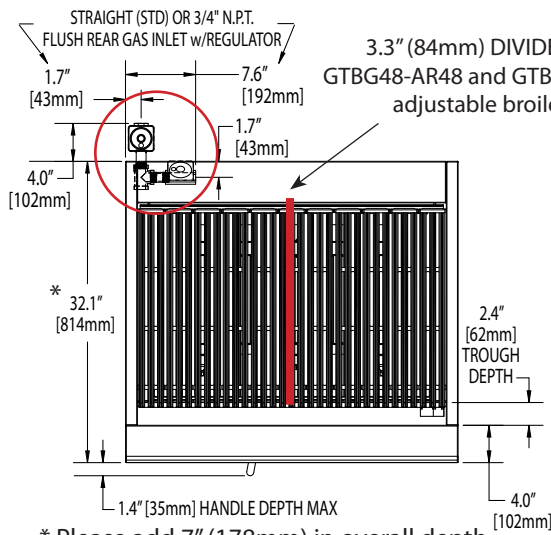

* Please add 7" (178mm) in overall depth with attachment condiment rail option.

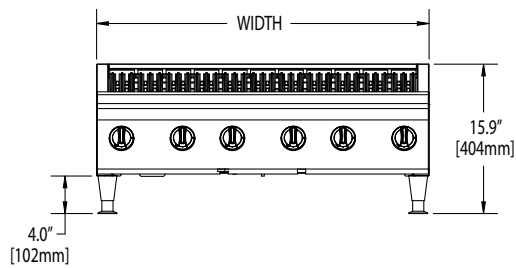

GAS CONNECTION OPTIONS FOR MODEL GTBG72-NR72 STRAIGHT (STD) OR NEARLY FLUSH 1" N.P.T REAR GAS INLET w/REGULATOR.

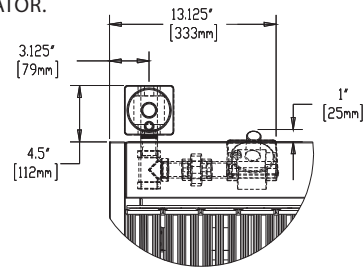

For use with Natural or Propane gas only. Gas input ratings shown for installations up to 2000 ft. (610m), above sea level. Please specify altitudes over 2000 ft. and gas type when ordering.

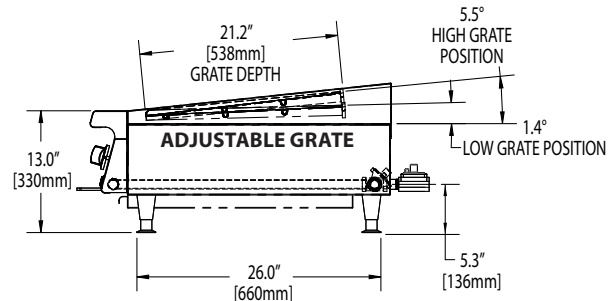
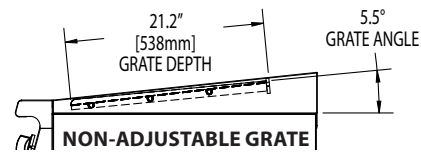

Model #	Width In (mm)	Height (w/std legs)	Depth In (mm)	Total Input (BTU)	Shipping Information	
					Lbs/Kg	Cu Ft
With Adjustable Grates						
GTBG24-AR24	23-5/8 (600)	13 (330)	32 (814)	72,000	283/129	19
GTBG36-AR36	35-7/16 (900)			108,000	391/178	26
GTBG48-AR48	47-1/4 (1200)			144,000	514/283	34
GTBG60-AR60	59-1/16 (1500)			180,000	635/288	41
With Non-Adjustable Grates						
GTBG24-NR24	23-5/8 (600)	13 (330)	32 (814)	72,000	283/129	18
GTBG36-NR36	35-7/16 (900)			108,000	391/178	25
GTBG48-NR48	47-1/4 (1200)			144,000	514/283	33
GTBG60-NR60	59-1/16 (1500)			180,000	635/288	40
GTBG72-NR72	70-7/8(1800)			216,000	690/313	47

SUPPLY OPERATING PRESSURE				MANIFOLD OPERATING PRESSURE				INSTALLATION CLEARANCES CLEARANCE: 0" FOR INSTALLATION IN NON-COMBUSTIBLE SURROUNDINGS ONLY
NATURAL GAS		PROPANE		NATURAL GAS		PROPANE		
"WC	MBar	"WC	Mbar	"WC	MBar	"WC	Mbar	
7	17.5	11	27.5	4.5	11	10	24.5	

Garland/U.S. Range products are not approved or authorized for home or residential use, but are intended for commercial applications only. Garland/U.S. Range will not provide service, warranty, maintenance or support of any kind other than in commercial applications.

Form# GTBG-AR-NR ((05/26/14))