

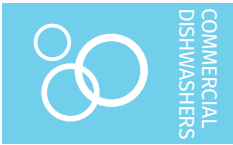

Project _____
 AIA # _____ SIS # _____
 Item # _____ Quantity _____ C.S.I. Section 114000



LXGePR *advansys* LOW TEMPERATURE Undercounter



LXGePR with 14" Stand



STANDARD FEATURES

- + Racks per hour – Light 38 / Normal 29
- + 1.14 gallons of water per rack
- + PuriRinse cycle (potable water rinse to remove chemical residue)
- + Low chemical alert indicators
- + Chemical pump “auto-prime”
- + Advanced service diagnostics
- + Clogged wash arm sensing
- + Custom cycle selection – light, normal
- + Automated delime cycle
- + Deep drawn stainless steel tank
- + Top-mounted controls with advanced digital cycle/temperature display
- + Revolving upper and lower anti-clogging wash arms
- + Snap in revolving upper and lower rinse arms
- + Removable stainless steel scrap screen
- + Corrosion resistant pump
- + Energy saver mode
- + Automatic pumped drain
- + 12" door opening
- + Dirty water indicator
- + Automatic fill
- + One dishrack – one glass/wine rack
- + Detergent, rinse aid and delime pumps standard
- + Electric tank heat
- + Auto clean cycle washes down inside of machine at shutdown
- + 6" leg stand (ships standard with LXGePR-2)
- + 14" leg stand (ships standard with LXGePR-1)

SPECIFIER STATEMENT

Specified unit will be a NSF rated Advansys undercounter glasswasher with PuriRinse, cold water sanitation. 38 or 29 racks per hour, 1.14 gallons per rack, autoclean, auto chemical sensing, LED temp and operator display, service diagnostics, rinse aid and detergent pumps. Constructed of stainless steel.

1 year parts and labor warranty.

OPTIONS & ACCESSORIES (Available at extra cost)

- Power cord kits
- DWT-LXe drain water tempering kit – to comply with plumbing codes
- Wine rack
- Splash reduction panel
- External casters

LXGe SERIES – LXGePR *advansys* LOW TEMPERATURE

Approved by _____ Date _____ Approved by _____ Date _____



LXGePR advansys LOW TEMPERATURE

Undercounter
(With 6" Leg Stand)

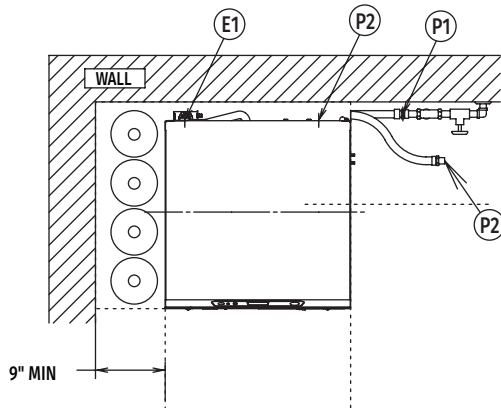

Top View

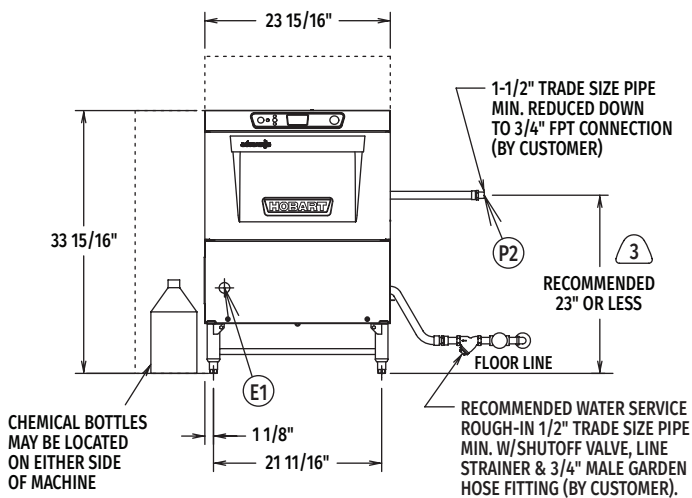

Front View with 6" Leg Stand

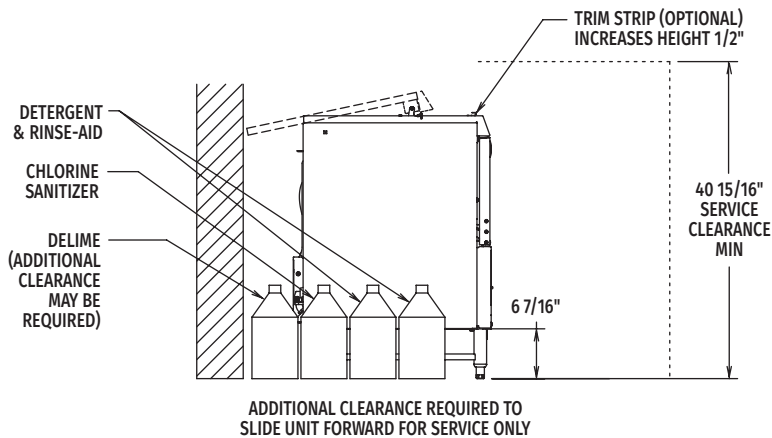

Left Side View with 6" Leg Stand

LEGEND

Electrical Connections	
E1	Electrical connection: 1-3/8" dia. hole for 1" trade size conduit; 4-5/8" AFF.
Plumbing Connections	
P1	Single fill and rinse connection: 3/4" female garden hose fitting on 6' long hose supplied with machine; 120°F (hot) minimum recommended for LXGePR.
P2	Drain connection: 5/8" barb fitting with 6' long hose supplied with machine.

WARNING: Plumbing and electrical connections should be made by qualified personnel who will observe all the applicable plumbing, sanitary, safety codes and National Electrical Code.

Heat Output, BTU/Hour	
Latent	Sensible
1,900	800

(E1) STANDARD ELECTRICAL OPTIONS

Tank Heat, Booster, Pump & Controls			
Voltage	Rated Amps	Minimum Supply Circuit Ampacity	Maximum Protective Device
120/60/1	15.4	20	20

NOTE: For supply connections, use copper wire only rated at 90°C minimum.

* This system requires three power wires which includes a current carrying neutral, an additional fourth wire must be provided for machine ground.

Accessory cord kit available for all models.

Dishmachine not provided with internal GFCI protection.

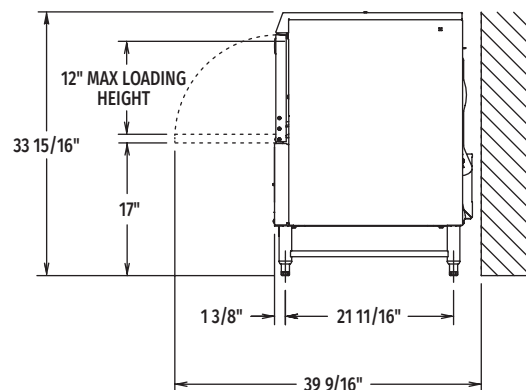

Right Side View with 6" Leg Stand



LXGePR advansys LOW TEMPERATURE

Undercounter
(With 14" Leg Stand)

SPECIFICATIONS

Capacities

Cycle Time (seconds)	Light 94 / Normal 124
Racks per Hour	Light 38 / Normal 29
Tank Capacity – Gallons	2.9

Motor Horsepower

Wash	.085
Rinse	0.19

Water Consumption

U.S. Gallons per Rack (maximum use)	1.14
U.S. Gallons per Hour (maximum use)	33.0
Peak Drain Flow – U.S. Gallons	4.0

Temperatures °F

Incoming Water Temperature (minimum recommended)	120
---	-----

Heating

Tank Heat, electric (kW)	1.8
Electric Booster (kW)	N/A

Standard 20" x 20" (508 x 508) Rack Complement

Flat	1
Peg	1

Shipping Weight (approximate)170 lbs.

Crated Dimensions

With 6" Leg Stand	27"W x 30"L x 37"H
With 14" Leg Stand	27"W x 30"L x 45"H

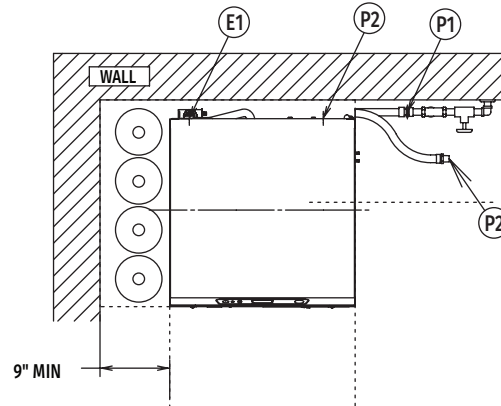

Top View

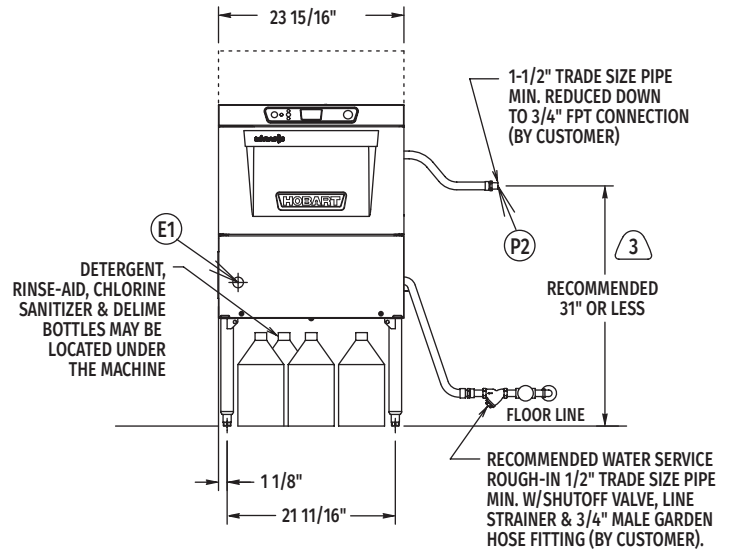

Front View with 14" Leg Stand

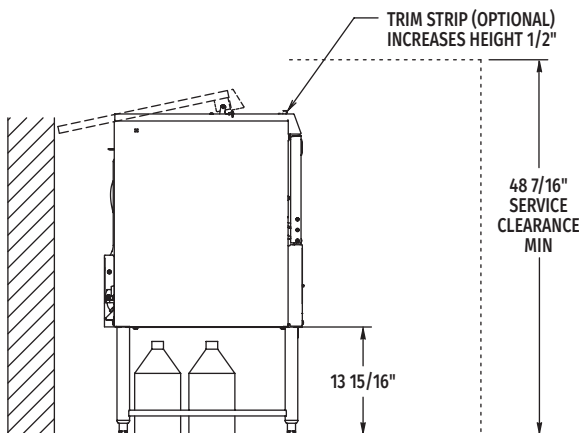

Left Side View with 14" Leg Stand

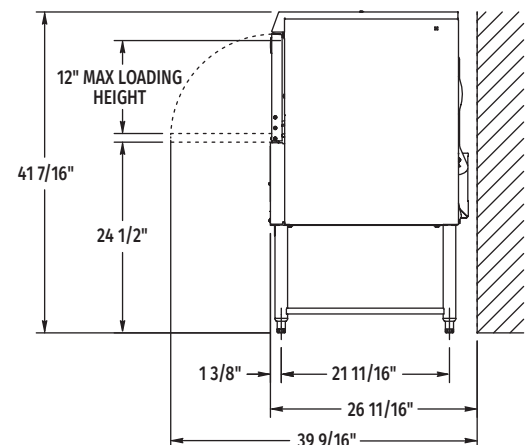

Right Side View with 14" Leg Stand

MODEL:
LXGePR TALL
00-950419
REV B