



WE RAISE THE BAR. WE SET THE STANDARD.

Project _____

Item Number _____

Quantity _____

MG8912

Duty Level

Light

Medium

Heavy



Meat and Food Grinder with #12 Hub

MADE IN THE USA

Model:

➤ MG8912: 1hp meat and food grinder



Meat and Food Grinder

Features:

- Medium duty meat and food grinder
- Grinds 8 to 12 lbs. per minute on first grind with a 3/16" (0.5cm) plate
- 1 hp motor with 1" (2.5cm) poly V belt drive
- Compact but powerful design
- Perfect for small schools, nursing homes, and restaurants
- Comes ready to grind with a 3/16" grind plate, X-knife, stainless steel feed pan, and aluminum stomper

Warranty:

- One year, on-site parts and labor

Standard Accessories:

- 12"x20" (30.5cmx50.8cm) stainless steel feed pan
- Aluminum stomper
- 3/16" (0.5cm) grind plate
- X-knife

Optional Accessories:

- 1/8" (0.3cm) grind plate
- 3/16" (0.5cm) grind plate
- 1/4" (0.6cm) grind plate
- 3/8" (1cm) grind plate
- 1/2" (1.3cm) grind plate
- X-knife
- 1/2" (1.3cm) stuffing tube
- 3/4" (1.9cm) stuffing tube
- Small plastic cover
- S-1B stand

Univex Corporation



Univex Corporation
www.Univexcorp.com

3 Old Rockingham Rd
Salem, NH 03079
United States of America

TEL: (800)258-6358
INTL TEL: (603)893-6191
FAX: (800)356-5614
INTL FAX: (603)893-1249



WE RAISE THE BAR. WE SET THE STANDARD.

Meat and Food Grinder

MG8912

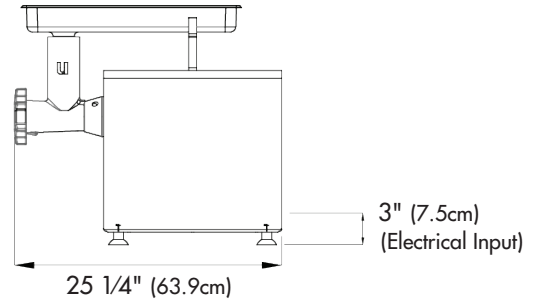
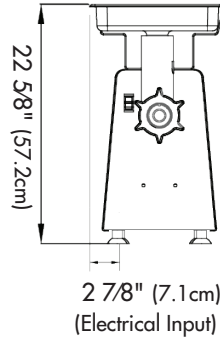
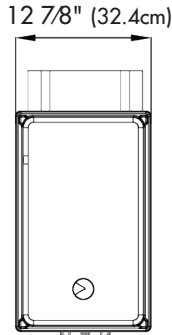

- Motor: 1 hp capacitor start, 1740RPM, ball bearing motor mounted on cushioned supports for noise and vibration reduction.
- Drive: 7:1 reduction produces increased torque. Uses a ribbed poly-V belt, 266RPM drive shaft supported by ball bearings in PTO.
- Drive Assembly: Completely enclosed in a powder coated ten gauge stainless steel cover and a powder coated steel cover.
- Switch: Rocker type double pole on/off conveniently located on the front side of the machine. Has a removable key to lock out machine.
- Meat Grinder: Aluminum housing with No.12 tapered hub. Housing is locked into the drive assembly, PTO housing, by a thumbscrew. Grinder housing has internal spiral flutes designed to shear and force product through the hardened steel knife.
- Feed Pan: 8.3 quarts (7.9 liters). 12"x20" (30.5 x 50.8cm)
- Feed Stomper: Aluminum stomper designed for ease of use and safety.

NEMA #: 5-15-P

Electrical Information (60Hz)				
	Voltage	Phase	hp(kW)	Amps
Standard Voltage	115	1	1 (0.75)	14.0
Optional Voltage	208-230	1	1 (0.75)	6.8-7.0

Shipping Information		
Net Weight	Shipping Weight	Overall Dimensions
99 lbs. (44.9Kg)	108 lbs. (49Kg)	24" (61cm) H x 18" (45.7cm) W x 25" (63.5cm) D



Univex Corporation
www.Univexcorp.com

3 Old Rockingham Rd
Salem, NH 03079
United States of America

TEL: (800)258-6358
INTL TEL: (603)893-6191
FAX: (800)356-5614
INTL FAX: (603)893-1249