

**REFRIGERATOR MANUFACTURER**  
**Turbo air**  
 more durable, efficient, beautiful

4184 E. Conant St.  
 Long Beach, CA 90808  
 Tel. 310-900-1000  
 Fax. 310-900-1077  
[www.turboairinc.com](http://www.turboairinc.com)

Project :	
Model # :	
Item # :	Qty :
Available W/H :	
Approval :	

## Glass Door Refrigerator

Reach-In Bottom Mount  
 Super Deluxe Series

**Model : MSR-49G-2**

### ≡ FEATURES & BENEFITS ≡

- **Self-cleaning condenser device** *Only at Turbo Air*

The accumulation of dust in the condenser causes the failure or breakdown of refrigerators. Refrigerators run normally until they reach a certain level of accumulation. At some point, when they are over the limit, their performance drops quickly resulting in damage to, or disposal of the stored products in refrigerators. The self-cleaning condenser device keeps the condenser clean and prevents system failure by automatically brushing daily.
- **Digital temperature control & monitor system**

  - Keep food products safe by maintaining constant temperatures.
  - Alarms that sound when doors are not sealed shut; protect against food spoilage that originate from cold air leaks.
  - Digital display allows for easy monitoring.
  - Programs interpret the condition of refrigeration systems by self-diagnosis.
  - Rapid cool-down functions (Turbo cooling).
  - Automatic evaporator fan motor delays.
- **Stainless steel interior & exterior**

The Turbo Air Super Deluxe glass door model is constructed with stainless steel exterior. The door is glass with AL frame. The interior is stainless steel that guarantees the utmost in cleanliness and long products life. The Super Deluxe can add a touch of style to the most refined setting.
- **Efficient refrigeration system**

Turbo Air's glass door refrigerators are designed with oversized and balanced (CFC Free R-134A) refrigeration systems. These include efficient evaporators and condensers for faster cooling and greater efficiency.
- **Double pane glass doors with Low-E glass**

Energy saving double pane glass doors are equipped with Low-emissivity glass, which reduce outer heat gain and decrease energy consumption. It enhances energy efficiency and minimizes condensation. Lightweight door construction also reduce door maintenance and bushing wear, which in turn facilitates smoother door openings.
- **High-density polyurethane insulation**
- **LED Interior lighting**
- **Ergonomically designed doors**

Customers' fatigue fades away with easy grip handles and doors that open effortlessly. Self-closing features make this the ultimate choice in customer convenience.
- **Adjustable, heavy duty, PE (polyethylene) coated wire shelves**
- **Bottom mount compressor**
- **Refrigerator holds 33°F ~ 38°F for the best in food preservation**



**Self-Cleaning  
 Condenser**



**NO MAINTENANCE REQUIRED**



ENERGY STAR®  
 Qualified

Model	Swing Door	CU./FT.	#of Shelves	HP	AMPS	Crated Weight (lbs.)	L x D x H <sup>†</sup> (inches)
MSR-49G-2	2	49	6	1/3	7	480	54 3/8 x 30 3/4 x 78 1/4

# Glass Door Refrigerator

Reach-In Bottom Mount  
Super Deluxe Series

## Model : MSR-49G-2

ELECTRICAL DATA	
Voltage	115/60/1
Plug Type	Ⓜ NEMA-5-15P
Full Load Amperes	7
Compressor HP	1/3
Feed Wires with Ground	3
Cord Length (ft.)	7
Refrigerant	R-134A
DIMENSIONAL DATA	
# of Doors	2
# of Racks Accepted	2
Net Capacity (cu. ft.)	49
Ext. Length Overall (in.)	54 <sup>3</sup> / <sub>8</sub> (1381mm)
Ext. Depth Overall (in.)*	30 <sup>3</sup> / <sub>4</sub> (781mm)
Ext. Height Overall (in.)†	78 <sup>1</sup> / <sub>4</sub> (1987mm)
Int. Length Overall (in.)	50 <sup>1</sup> / <sub>2</sub> (1282mm)
Int. Depth Overall (in.)	26 <sup>1</sup> / <sub>4</sub> (666mm)
Int. Height Overall (in.)	60 (1524mm)
Gross Weight (lbs.)	480
# of Shelves	6
Shelf Size (L x D) (in.)	24 <sup>5</sup> / <sub>8</sub> x 23 <sup>1</sup> / <sub>2</sub>

Design and specifications subject to change without notice.  
Actual shipping weight may differ due to extra packing materials for product protection.  
\* Depth does not include 1-1/2" for glass door handles.  
† Height does not include 5" caster height or 6" optional legs.

### ■ WARRANTY : 3 Year Parts and Labor Warranty Additional 2 Year Warranty on Compressor

- Door locks standard
- Self-contained system
- Standard 4" dia. swivel casters with locks on the front set
- Easy replaceable one piece magnetic door gaskets
- Solid and sturdy grille design
- Legs available (optional)
- Full size and half pan racks available (optional)

### ■ OPTIONAL ACCESSORIES :

- 5" caster, 1/2" diameter & 13 TPI: M726500100 (non-brake), M726500200 (w/ brake)
- 6" stainless steel leg: 30221M0600
- Additional PE coated wire shelf: 30278L0400 (Left), 30278L0500 (Right)
- Half door bun tray rack: TSP-2224 (each holds up to six 18"L x 26"D sheet pans)
- Full door bun tray rack: TSP-2250 (each holds up to fifteen 18"L x 26"D sheet pans)

## PLAN VIEW

(unit : inch)

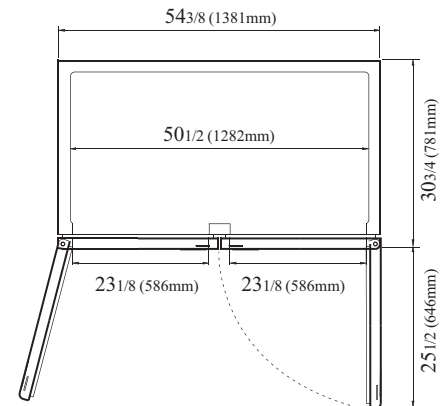

PLAN VIEW

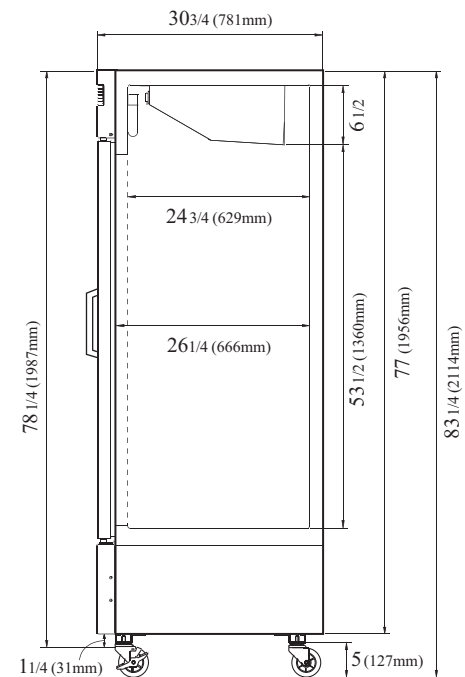

SIDE VIEW

Ver.201601



ENERGY STAR®  
Qualified

- Turbo Air : 800-627-0032
- GK : 800-500-3519
- Warranty : 800-381-7770
- AC : 888-900-1002

REFRIGERATOR MANUFACTURER  
**Turbo air**

**GERMAN KNIFE**

**RADIANCE**

**GREEN WORLD**

AIR CONDITIONER MANUFACTURER  
**Turbo air**