



BEVERAGE-AIR

Project: _____	AIA#
Item: _____	
Location: _____	SIS#
Approved: _____	

MT21™ MERCHANDISER: HINGED DOOR MODEL

MARKETEER™ MERCHANDISERS

MT21 Black Hinged Door Model
Hydrocarbon Series

MODEL:
MT21-1B



3 Year Parts / Labor Warranty
Additional 4 Year Compressor Warranty

CABINET CONSTRUCTION

- Standard cabinet exterior finish is heavy duty steel with a black baked on durable coating
- Heavy duty interior construction includes white coated steel
- Mechanical temperature control
- One piece grille
- Double pane lowE argon filled glass doors feature outside pane that is tempered for added safety
- Self-closing glass doors with pocket door handles
- LED lighting
- Eight (8) shelves standard
- Leveling feet

OPTIONS & ACCESSORIES

- Extra shelves and clips

REFRIGERATION SYSTEM

- Refrigeration system uses R290 refrigerant to comply with all environmental standards
- Low maintenance condenser



Please verify qualifying units by visiting:
www.energystar.gov/cfs

3779 Champion Blvd., Winston-Salem, NC 27105
1-888-845-9800 Fax: 1-336-245-6453
Beverage-Air.com Sales@bevair.com



BEVERAGE-AIR®

MODEL	MT21-1B
EXTERNAL DIMENSIONAL DATA	
Width Overall	39 1/8"
Depth Overall	24 1/2"
Height Overall	61 7/32"
Number of Doors	2
Depth with Door Open 90°	35 5/64"
Door Opening (in)	19 1/8" x 44 3/4"
INTERNAL DIMENSIONAL DATA	
NET Capacity (cubic ft.)	16.77
Internal Width Overall (in)	36 7/32"
Internal Depth Overall (in)	17 23/32"
Internal Height Overall (in)	39 3/4"
Internal Height Useable (in)	36 19/32"
Number of Shelves	8
ELECTRICAL DATA	
Full Load Amperes 115/60/1	3.6
REFRIGERATION DATA	
Horsepower	1/6
WEIGHT DATA	
Gross Weight	308 lbs
Height - Crated	80"
Width - Crated	43"
Depth - Crated	28"

Glass Hinged Door Model Model: MT21-1B

Model Views

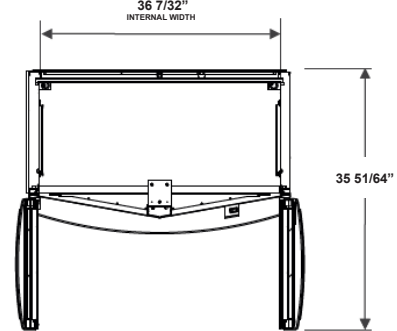

PLAN VIEW

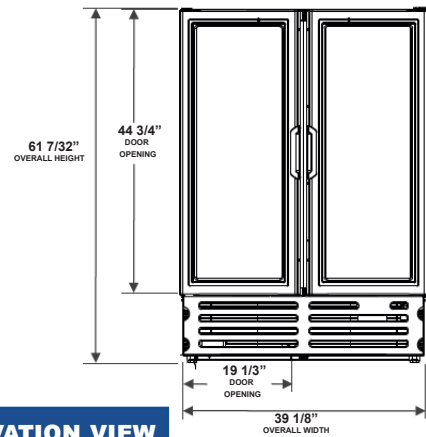

ELEVATION VIEW

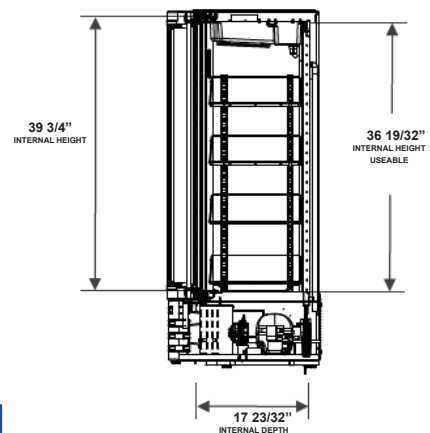

SIDE VIEW

ELECTRICAL CONNECTION



115/60/1
NEMA 5-15P

Unit pre-wired at
factory and include
cord and plug set.



3779 Champion Blvd., Winston-Salem, NC 27105 1-888-845-9800 Fax: 1-336-245-6453 Beverage-Air.com Sales@bevair.com

an Ali Group Company



The Spirit of Excellence