

GLASS DISPLAY CHEST FREEZER MERCHANDISERS

- MODEL: MXF25CHC-2 MXF32CHC-3 MXF40CHC-4 MXF48CHC-5
 MXF54CHC-6 MXF64CHC-7 MXF72CHC-8



MXF25CHC-2



MXF32CHC-3



MXF40CHC-4



MXF48CHC-5



MXF54CHC-6



MXF64CHC-7



MXF72CHC-8

This line of Glass Display Freezer Merchandisers offer a spacious interiors that allow you to store ice cream and frozen novelties in an elegant presentation, with size options to meet your specific application requirements. Capacities range from 3.8 to 14.3 cubic feet (108 to 405 liters). Each unit has thick wall insulation and a white powder coated finish for easy cleaning.

FEATURES AND CONSTRUCTION

- Exterior Material: durable, white powder coated, baked on enamel steel
- Interior Material: painted white powder coated steel
- Thick, 2.5" foamed in-place, environmentally friendly, polyurethane insulation
- Clear, curved glass sliding lids with easy grip handles
- Lid lock and key set
- Flat wire baskets with 3 compartments
- Interior LED lighting makes it easier to see selection and enhance product's appearance
- Molded plastic lid frame is heated to prevent frost and ice build-up
- Equipped with an internal condensate evaporator pan, so no floor drain is needed
- Four (4) or six (6) Heavy-duty casters (1 with brake)
- Removable rubber bumper guards and side grill

NET STORAGE CAPACITY

MXF25CHC-2.....	3.81 Cu Ft (108 L)
MXF32CHC-3.....	4.87 Cu Ft (138 L)
MXF40CHC-4.....	6.71 Cu Ft (190 L)
MXF48CHC-5.....	8.62 Cu Ft (244 L)
MXF54CHC-6.....	9.96 Cu Ft (282 L)
MXF64CHC-7.....	12.36 Cu Ft (350 L)
MXF72CHC-8.....	14.30 Cu Ft (405 L)

TEMPERATURE

Holding temperature -18°F to 10°F (-28°C to -12°C)

- Utilizes a reliable, easily maintained cold wall system
- Easy to read external analog thermometer display

ELECTRIC

115V / 60Hz / 1Ph
 (230V / 50-60Hz / 1Ph is available as an option)
 6' (2m) NEMA 5-15P cord set included

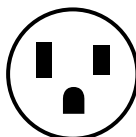

NEMA 5-15P

3RD PARTY APPROVALS



Intertek

Certified to ANSI NSF 7



Intertek

Certified to ANSI UL 471



DOE 2018 Compliant



2020 Compliant

MAXX COLD WARRANTY (USA / CANADA)

Contact Maxx Cold for warranty statement at
 TechnicalServices@TheLegacyCompanies.com or 877.368.2797

MXF25CHC-2

MXF32CHC-3 / MXF40CHC-3 / MXF48CHC-5 / MXF54CHC-6 / MXF64CHC-7 / MXF72CHC-8

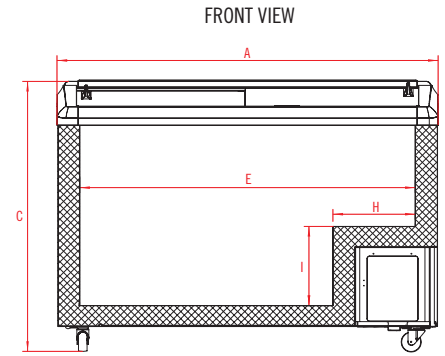
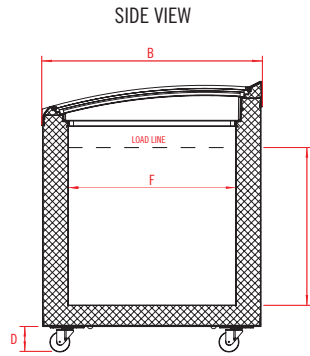
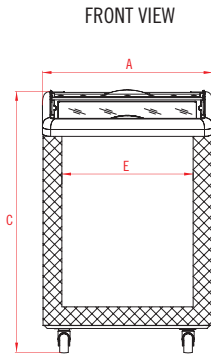
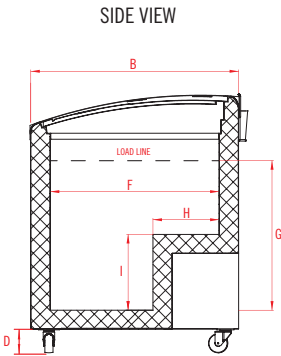

MODEL	EXTERNAL DIMENSIONS				INTERNAL DIMENSIONS				
	A	B	C	D	E	F	G	H	I
MXF25CHC-2	24.6 in 625 mm	27.6 in 700 mm	32.6 in 828 mm	3 in 76.2 mm	18.5 in 470 mm	21.7 in 550 mm	18.9 in 480 mm	8.7 in 220 mm	9.7 in 245 mm
MXF32CHC-3	31.5 in 800 mm	27.5 in 697 mm	33.5 in 850 mm	3 in 76.2 mm	25.8 in 656 mm	20.9 in 530 mm	19.6 in 498 mm	10.2 in 260 mm	9.8 in 250 mm
MXF40CHC-4	39.4 in 1000 mm	27.5 in 697 mm	33.5 in 850 mm	3 in 76.2 mm	33.7 in 856 mm	20.9 in 530 mm	19.6 in 498 mm	10.2 in 260 mm	9.8 in 250 mm
MXF48CHC-5	47.4 in 1204 mm	27.5 in 697 mm	33.5 in 850 mm	3 in 76.2 mm	41.7 in 1060 mm	20.9 in 530 mm	19.6 in 498 mm	10.2 in 260 mm	9.8 in 250 mm
MXF54CHC-6	53.2 in 1350 mm	27.5 in 697 mm	33.5 in 850 mm	3 in 76.2 mm	47.5 in 1206 mm	20.9 in 530 mm	19.6 in 498 mm	10.2 in 260 mm	9.8 in 250 mm
MXF64CHC-7	63.4 in 1610 mm	27.5 in 697 mm	33.5 in 850 mm	3 in 76.2 mm	57.7 in 1466 mm	20.9 in 530 mm	19.6 in 498 mm	10.2 in 260 mm	9.8 in 250 mm
MXF72CHC-8	71.7 in 1820 mm	27.5 in 697 mm	33.5 in 850 mm	3 in 76.2 mm	66 in 1676 mm	20.9 in 530 mm	19.6 in 498 mm	10.2 in 260 mm	9.8 in 250 mm

MODEL	ELECTRICAL	NET VOLUME Cu Ft (L)	REFRIGERANT AND CHARGE SIZE	NET WEIGHT Lbs (kg)	HP	AMPS	BASKETS	NEMA PLUG
MXF25CHC-2	115V / 60Hz / 1Ph	3.81 (108)	R290a 2.43 oz / 69 g	103.6 (47)	1/9	1.0A	2	5-15P
MXF32CHC-3	115V / 60Hz / 1Ph	4.87 (138)	R290a 2.65 oz / 75 g	114.6 (52)	1/7	1.3A	3	5-15P
MXF40CHC-4	115V / 60Hz / 1Ph	6.71 (190)	R290a 3 oz / 85 g	130.1 (59)	1/5	1.4A	4	5-15P
MXF48CHC-5	115V / 60Hz / 1Ph	8.62 (244)	R290a 3.53 oz / 100 g	152.1 (69)	1/4	2.0A	5	5-15P
MXF54CHC-6	115V / 60Hz / 1Ph	9.96 (282)	R290a 4.06 oz / 115 g	165.4 (75)	1/4	2.0A	6	5-15P
MXF64CHC-7	115V / 60Hz / 1Ph	12.36 (350)	R290a 4.23 oz / 120 g	187.4 (85)	1/4+	2.0A	7	5-15P
MXF72CHC-8	115V / 60Hz / 1Ph	14.30 (405)	R290a 4.76 oz / 135 g	231.5 (105)	1/2	2.8A	8	5-15P