



FOOD EQUIPMENT

SERVING THE FOOD INDUSTRY SINCE 1951

12" x 15" RIBBED PANINI GRILL WITH TIMER

Item: 42912

Model: PG-CN-0679-RT



Authorized Dealer



WARRANTY
PARTS AND LABOR



FOOD EQUIPMENT

12"x15" RIBBED PANINI GRILL WITH TIMER



Thermostat Control



Removable Drip Tray



Removabe Timer (2 AAA Batteries required)

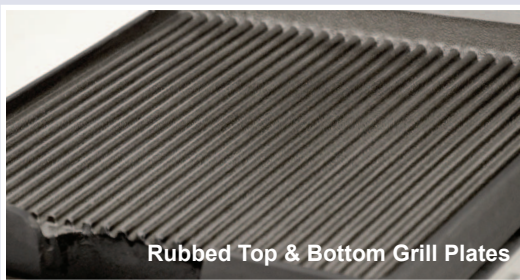

Rubbed Top & Bottom Grill Plates



Heavy Duty Grill Brush

Features

- Ideal for sandwiches, burgers, quesadillas, panini, focaccia, breakfast sandwiches and pita sandwiches
- Constructed with a stainless steel body and heavy-duty cast iron grill which ensures easy cleaning
- Equipped with timer to maximize work efficiency
- Easy to remove drip tray
- Heat-resistant handles for safe operations

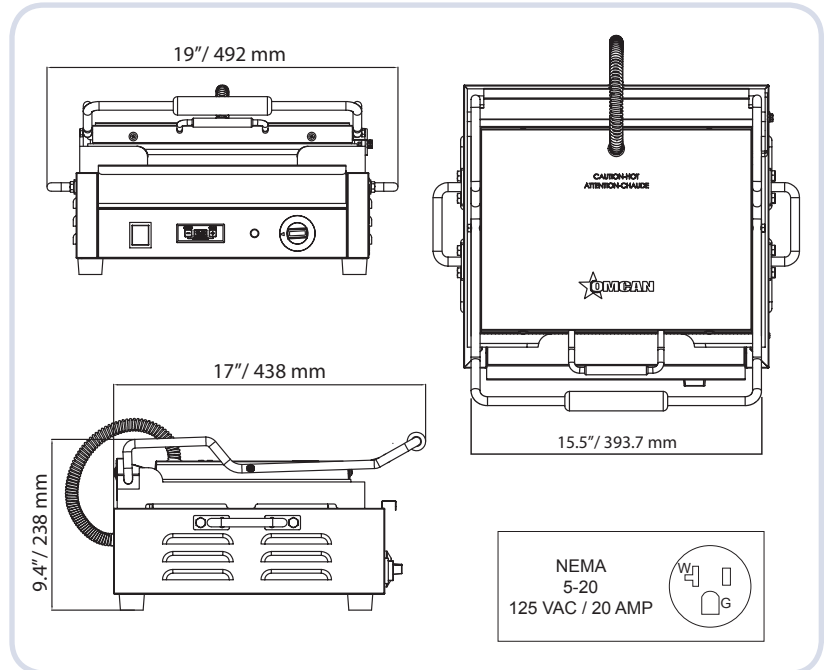

TECHNICAL SPECIFICATION

ITEM NUMBER	42912
MODEL	PG-CN-0679-RT
GRILL SURFACE	12" x 15" / 304.8 x 381 mm
THERMOSTAT CONTROL	60-300 °C / 140-572 °F
WATTS	1800
ELECTRIC	120V/60Hz/1
TOP GRILL	Ribbed
BOTTOM GRILL	Ribbed
WEIGHT	70 lbs.
DIMENSIONS (WDH)	19" x 17" x 9.4"(Close), 24.25"(Open) / 492 x 438 x 238 mm(Close), 616 mm (Open)
GROSS DIMENSIONS	23" x 20.25" x 13.5" / 584 x 514 x 343 mm

OMCAN INC.

Telephone: 1-800-465-0234
 Fax: (905) 607-0234
 Email: sales@omcan.com
 Website: www.omcan.com



Follow us to keep up to date with the latest news and offers

