

Model:
RICI-54

Solid Door / Reach-In

 **Cooler**

 **Stainless**

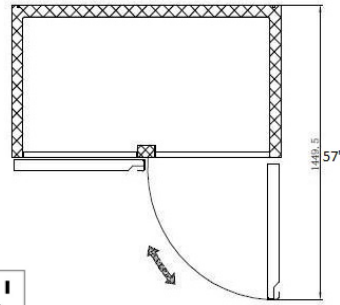
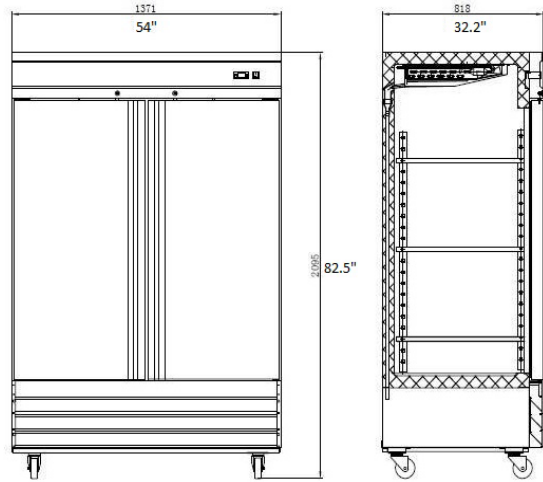

5-15P



Doors	Shelves	Refrigerant	HP	Power	Amps.	Cu.ft.	Weight(lbs.)
2	6	R290	1/2+	115/60/1	9.4	47	397

FEATURES

- S/S interior and S/S exterior** retains attractive finish longer.
- Rounded corner** design inside of the cabinet makes it easy to clean it.
- Standard door features:**
 - ✓ Heavy-duty pull handle.
 - ✓ Each door has two spring hinges, that it makes the door to self-closing enduring quality.
- Refrigeration system** holds 33°F to 41°F (0.5°C to 5°C) for the best in food preservation.
- Electronic control system:**
 - ✓ Adjustable temperature set point and defrost frequency.
 - ✓ Error codes to diagnose service issues.
- Shelves:** Adjustable, heavy duty PVC coated shelves.
- Standard heavy-duty casters** make it easy to move and clean underneath.
- "No Stoop" lower shelf.
- Storage on top of cabinet.
- Easily accessible condenser coil for cleaning, and easy service access.
- Simple installation with no plumbing required.