



REFRIGERATION

SERVING THE FOOD INDUSTRY SINCE 1951

36-INCH SQUARE GLASS FLOOR REFRIGERATED DISPLAY CASE

Item: 44382

Model: RS-CN-0271-S



OMCAN'S SQUARE GLASS FLOOR REFRIGERATED DISPLAY CASE

provides an economical solution for displaying your products. Features an interior lighting under each shelves as well as digital temperature controller for easy usage.



Authorized Dealer



WARRANTY
PARTS AND LABOR



update: Feb 17, 2022

REFRIGERATION

36-INCH SQUARE GLASS FLOOR REFRIGERATED DISPLAY CASE

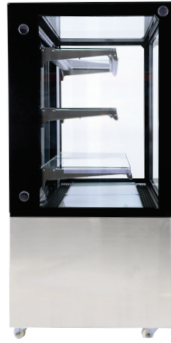

FEATURES

- Brilliant LED illumination under each shelves
- Digital temperature controller & display
- Stainless steel base
- Adjustable chrome plated shelves
- Four-sided double glass
- Automatic defrost
- Ventilated cooling system

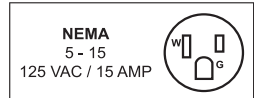

TECHNICAL SPECIFICATION

ITEM NUMBER	44382
MODEL	RS-CN-0271-S
POWER	535W
COMPRESSOR POWER	3/8 HP / 510 W
CAPACITY	390 L / 13.77 cu. ft.
LAMP POWER	23W
TEMPERATURE RANGE	0-12°C / 32-54°F
REFRIGERANT	R290
BLOWING GAS	Front
TYPE OF CLIMATE	4
RATED CURRENT	6.3A
SHELF SIZE	36.8" x 12" / 935 x 305mm 36.8" x 14" / 935 x 356mm
NET DIMENSIONS	36" x 26.8" x 56" / 914 x 681 x 1422mm
GROSS DIMENSIONS	42" x 31" x 66" / 1067 x 787 x 1676mm
NET WEIGHT	355lbs/ 161kgs
GROSS WEIGHT	394.6lbs/ 179kgs



Digital temperature controller & display

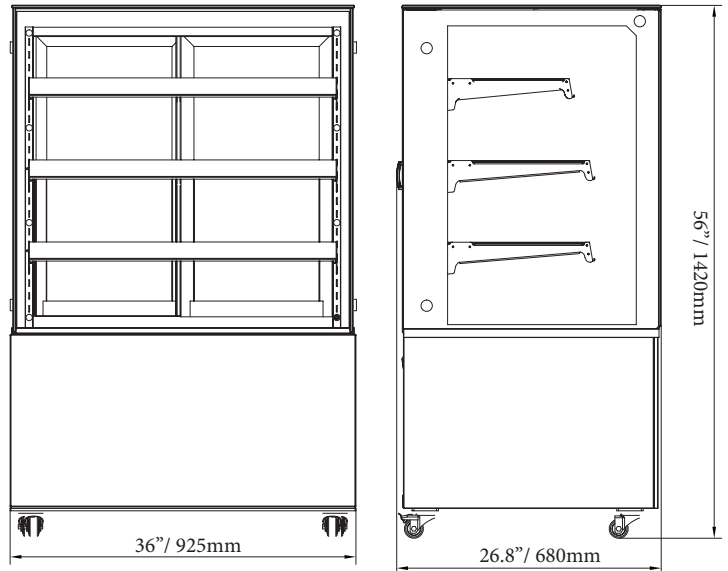

Item is shipped on pallet.

update: Feb 17, 2022

OMCAN INC.

Telephone: 1-800-465-0234
 Fax: (905) 607-0234
 Email: sales@omcan.com
 Website: www.omcan.com



Follow us to keep up to date with the latest news and offers



2018E&OE