

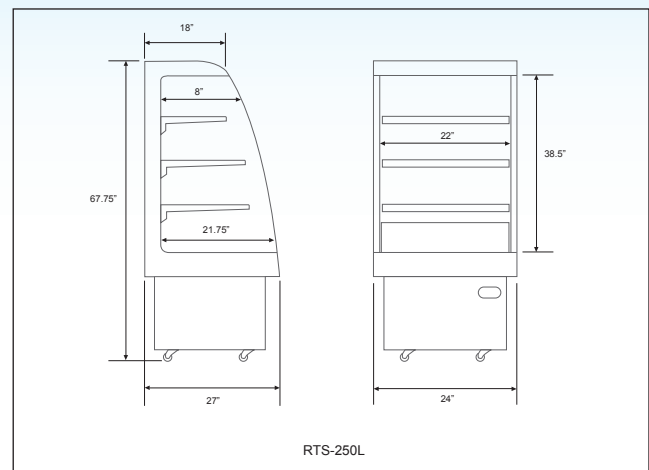

Open Refrigerated Display Case

Features:

- LED lighting
- Digital temperature controls
- Adjustable Shelf Positions
- Pull down curtain
- Casters



RTS-250L

Specifications

Model	RTS-250L
Rated Input Power	650 W
Electrical Heating Element	400 W
Electrical	110 V / 60 Hz
Lamp Power (W)	1.44*4(LED)
Temperature	2~10°C
Refrigerant & Injection	R134a (600g)
Blowing Gas	XPS
Type of Climate	6
Rated Current(A)	10
Weight	282 lbs.
Packaging Weight	298 lbs.
Dimensions (DWH)	27" x 24" x 67.75"
Inner Dimensions	21.75" x 22" x 38.5"
Shelf Size	15" x 21.75" (2pc.) 12" x 21.75" (1pc.)
Packaging Dimensions	30" x 28" x 70"
Item #	25825



Mississauga, Ontario, Canada

Niagara Falls, New York, USA

Tel: (905) 828-0234 Toll-Free: 1-800-465-0234 Fax: (905) 607-0234 Email: sales@omcan.com

www.omcan.com