



Manufacturer and Supplier of  
**Restaurant Equipment**  
 and **Display Cases**  
 for the Food Service Industry



# MODEL: SC-72-PPT

## PRODUCT FEATURES

### PIZZA PREP

- Refrigerated rail to hold 3 full size pans
- Stainless Steel front
- 2 1/2 pull out Stainless Steel doors
- Self-contained
- 20" marble top
- Integrated door light
- Holds 33°-41°F temperatures
- Compressor can be serviced easily
- Environmentally friendly 134A refrigerant
- Full size doors designed to store dough pans
- Tray slides (optional)

- |                   |                         |
|-------------------|-------------------------|
| Casters           | 5" Casters Optional     |
| Warranty          | 1 yr Parts & Compressor |
| Front Door        | Stainless Steel         |
| Front Motor Cover | Anodized Aluminum       |
| Interior Walls    | Stainless Steel         |
| Outside Back      | Galvanized              |

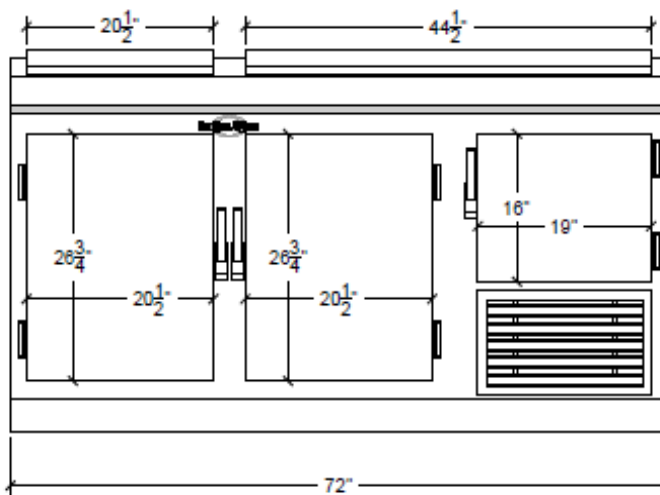
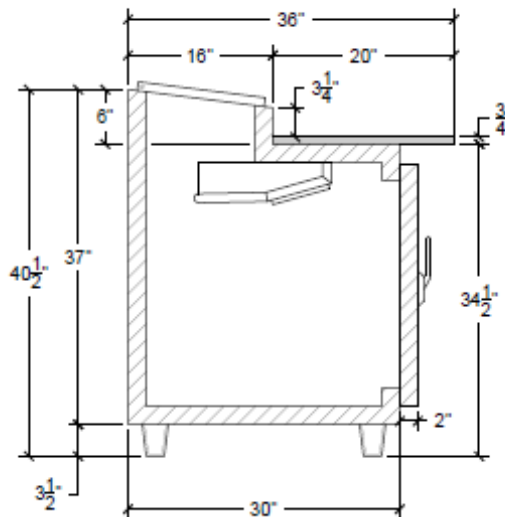

### Product Specifications

Dimensions	Doors	Pans	Cooling Cycle	Refrigerant	HP	Power	Ampr.	BTU	Freon (oz)
72" x 34" x 42"	2 1/2	18	33-41	134a	1/3	115/60/1	12.5	1400	10

### Additional Models

Model #	Doors	Pans	Cooling Cycle	Refrigerant	HP	Power	Ampr.	BTU	Freon (oz)
SC-48-PPT	1 1/2	12	33-41	134a	1/3	115/60/1	9.8	1100	11.5
SC-96-PPT	3 1/2	24	33-41	134a	1/2	115/60/1	14	1850	15

\* Model number designates product length. Due to product improvement, we reserve the right to change specifications without notice.