

Project _____

Item Number _____

Quantity _____

SL280LH/SL280LB



SL280LH / SL280LB SILVERLINE Spiral Mixers with Attached Lifter

Models:

- SL280LH: 615Lbs (280Kg) Spiral Mixer
- SL280LB: 615Lbs (280Kg) Spiral Mixer



Spiral Mixer
with Attached Lifter

Features:

- Stainless steel bowl, spiral dough hook, and shaft
- Separate bowl and agitator motors
- Has two speeds and reverse function
- Control board has separate timers for 1st and 2nd speed
- Mixer is equipped with built in lifter for lifting and discharge of mixed products
- Lifter can tilt machine to the right or left (must specify when ordering)
- Difference between H and B models is the height of the lifter (one for bench top and one for hoppers)
- Safety switches protect operator from injury if bowl lid is open
- Powerful belt drive provides low vibration, low noise, and economical maintenance for years of reliable service

Univex Corporation

Dough hook:

1st speed: 95rpm

2nd speed: 190rpm

Bowl Speed: 15rpm

Warranty:

- One year, on-site parts and labor



WE RAISE THE BAR. WE SET THE STANDARD.

SILVERLINE Spiral Mixer with Attached Lifter

SL280LH/SL280LB

SL280LH

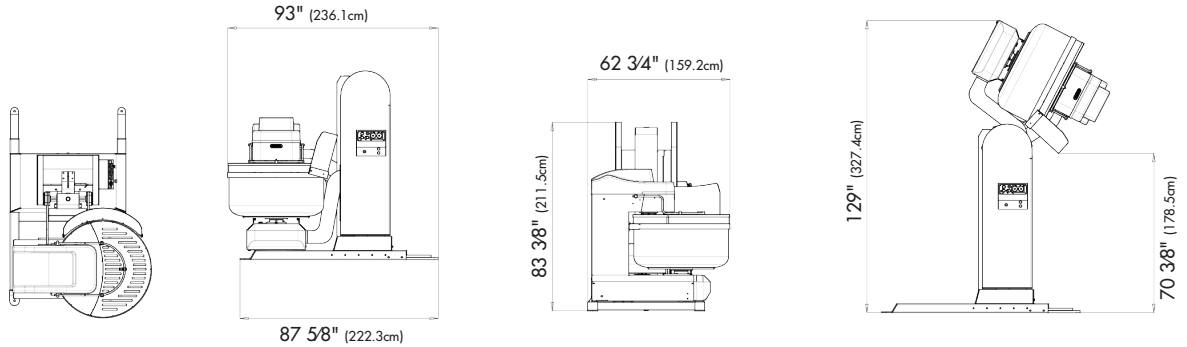

SL280LB

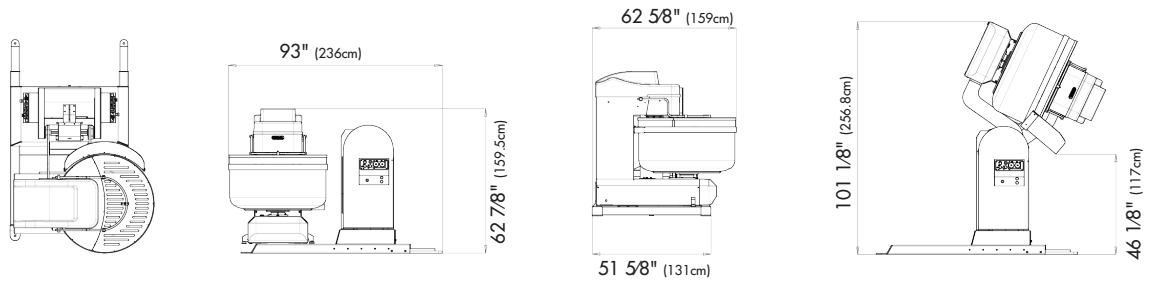

Electrical Information (60Hz)

Model	Voltage	Phase	Spiral hp(kW)	Bowl hp(kW)	Lifter hp(kW)	Total hp(kW)	Spiral Amps	Bowl Amps	Lifter Amps	Total Amps
SL280LH	220	3	18 (13.2)	1 (.75)	3 (2.2)	22 (16.15)	63.5	4.48	13	68
SL280LH Optional Voltage	400	3	18 (13.2)	1 (.75)	3 (2.2)	22 (16.15)	31.75	2.24	6.5	34
SL280LB	220	3	18 (13.2)	1 (.75)	3 (2.2)	22 (16.15)	63.5	4.48	13	68
SL280LB Optional Voltage	400	3	18 (13.2)	1 (.75)	3 (2.2)	22 (16.15)	31.75	2.24	6.5	34

Transmission: Heavy duty low noise, low vibration belt drive.

Plug Info:

Bowl Guard: Swings open for full access to bowl. Guard must be closed for mixer operation.

Hard Wire With Shutoff

Controls: Control panel with manual timers. Separate timers for high and low speed. Security key for manual use. Bowl reverse direction switch.

Shipping Information

Model	Net Weight	Shipping Weight	Overall Dimensions
SL280LH	4,409 lbs. (2,000Kg)	4,759 lbs. (2,159Kg)	91" (231.1cm) H x 101" (256.5cm) W x 96" (243.8cm) D
SL280LB	3,748 lbs. (1,700Kg)	4,098 lbs. (1,859Kg)	71" (180.3cm) H x 101" (256.5cm) W x 96" (243.8cm) D



Univex Corporation
www.Univexcorp.com

3 Old Rockingham Rd
Salem, NH 03079
United States of America

TEL: (800)258-6358
INTL TEL: (603)893-6191
FAX: (800)356-5614
INTL FAX: (603)893-1249