



BEVERAGE-AIR

Project: _____	AIA#
Item: _____	
Location: _____	SIS#
Approved: _____	

SPE27HC SANDWICH PREP: STANDARD TOP

FOOD PREPARATION TABLES

SPE27HC Sandwich Prep Table

Hydrocarbon Series

MODEL:
SPE27HC-B



3 Year Parts/Labor Warranty
Additional 4 Year Compressor Warranty

CABINET CONSTRUCTION

- Stainless steel front, sides, top, door and grille (galvanized back & bottom)
- Interior liner is made of corrosion resistant aluminum
- Full electronic control
- Removable hoods made of matching stainless steel
- Airflow assures that product in open containers is kept below 41°F and above freezing
- Self-closing door with 120° stay-open feature on cartridge style hinges
- Snap-in magnetic gaskets for positive door seal
- Painted aluminum door handle
- 6" Casters, 2 with brakes standard
- 10" Wide cutting board constructed of white polyethylene plastic
- Cutting board removable for cleaning
- Two (2) epoxy-coated steel wire shelves
- Eight (8) 1/6 4" deep pans constructed of polycarbonate plastic

OPTIONS & ACCESSORIES

- Stainless steel back
- Stainless steel interior
- Left hinged door (at time of order)
- Clear lid
- Door lock
- Overshelves (single or double)
- Crumb catcher kit
- Richlite cutting board
- Night cover
- Epoxy coated shelves
- Shelf clips
- Shelf dividers
- Bottle organizer
- Bun rack
- Pan supports
- Pan support crossbar
- Pan configuration
- 6" Legs or 3" casters
- Low profile casters
- Remote option* (see note on back page)

REFRIGERATION SYSTEM

- Uses environmentally friendly, energy efficient R290 refrigerant, and meets all regulatory requirements for CARB, SNAP, DOE & more
- Adaptive defrost
- Epoxy coated evaporator coil
- Enhanced airflow maintains temperatures between 36° - 38°F



Please verify qualifying units by visiting:
www.energystar.gov/cfs

3779 Champion Blvd., Winston-Salem, NC 27105
1-888-845-9800 Fax: 1-336-245-6453
Beverage-Air.com Sales@bevair.com



BEVERAGE-AIR

Food Preparation Table: Standard Top Model: SPE27HC-B

MODEL	SPE27HC-B
EXTERNAL DIMENSIONAL DATA	
Width Overall	27"
Depth Overall	31"
Height Overall (with casters)	45 ³ / ₈ "
Number Doors	1
Depth with Door Open 90°	55 ³ / ₈ "
Door Opening	22 ⁵ / ₈ " x 21 ⁵ / ₈ "
Width, Cutting Board	10"
INTERNAL DIMENSIONAL DATA	
NET Capacity (cubic ft.)	6.91
Internal Width Overall (in)	23"
Internal Depth Overall (in)	23 ¹ / ₂ "
Internal Height Usable (in)	23"
No. of Shelves	2
No. of Pans	8
ELECTRICAL DATA	
Full Load Amperes	2.0
REFRIGERATION DATA	
Horsepower	1/10
Capacity (BTU/Hr)	1110
Heat Rejection (BTU/Hr)	1665
Charge (lbs/grams)	0.1102/50
SHIPPING DATA	
Gross Weight - Crated	202 lbs
Height - Crated	46"
Width - Crated	30"
Depth - Crated	33"

*NOTE: Remote units are field wired and come with 6" legs.
Refrigerant must be specified at time of order.

Model Views

Required Clearance: 3 ³/₄" bottom & 2" rear

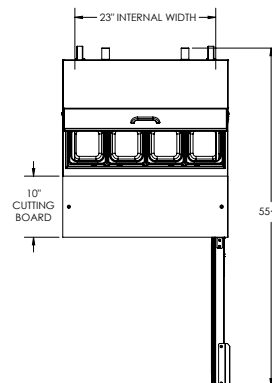

PLAN VIEW

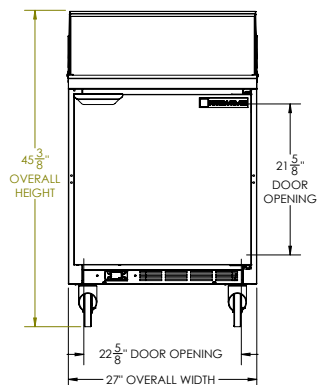

ELEVATION VIEW

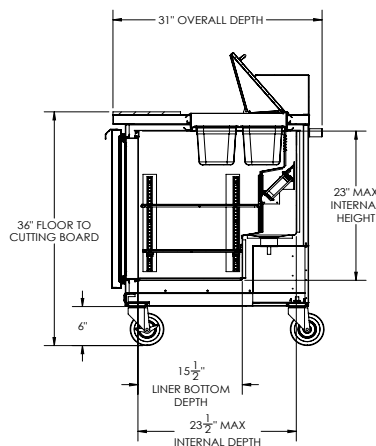

SIDE VIEW

ELECTRICAL CONNECTION



115/60/1
NEMA 5-15P

Unit pre-wired at factory and include 8' long cord and plug set.



3779 Champion Blvd., Winston-Salem, NC 27105 1-888-845-9800 Fax: 1-336-245-6453 Beverage-Air.com Sales@bevoir.com

an Ali Group Company



The Spirit of Excellence