

REFRIGERATOR MANUFACTURER
Turbo air
 more durable, efficient, beautiful

4184 E. Conant St.
 Long Beach, CA 90808
 Tel. 310-900-1000
 Fax. 310-900-1077
www.turboairinc.com

Project :	
Model # :	
Item # :	Qty :
Available W/H :	
Approval :	

Bottle Coolers

*Underbar Equipment
 Super Deluxe Series*

Patented Self-Cleaning Condenser



This product is equipped with a fine mesh filter to the front of the condenser to catch dust, and a rotating brush that moves up and down daily to remove excess buildup outward and away.

Model : TBC-80SD/SB-N



TBC-80SD-N



TBC-80SB-N

≡ FEATURES & BENEFITS ≡

- Self-Cleaning Condenser**
 The accumulation of dust in the condenser can cause the failure or breakdown of refrigerators. Refrigerators run normally until they reach a certain level of accumulation. At some point, when they are over the limit, their performance drops quickly resulting in damage to, or disposal of the stored products inside. The Self-Cleaning Condenser device keeps the condenser clean and prevents system failure by automatically brushing daily.
- Hydrocarbon refrigerants (R-290)**
 With innovative and eco-friendly technology, Turbo Air brings you hydrocarbon refrigerators designed to meet DOE's Energy Conservation Standards in 2017 and to use EPA's SNAP Program approved HC refrigerants. Hydrocarbon refrigerants do not deplete the ozone layer and have very low contribution to global warming (ODP-0, GWP-3).
- Forced air cooling system**
 Positive guided forced air cooling system chills bottles on top first.
- High-density polyurethane insulation**
 The entire cabinet structure is foamed-in-place using high density, HCFC free polyurethane insulation.
- Adjustable, heavy duty, PE (polyethylene) coated dividers**
- Side mount compressor unit**
 With compressors positioned on the side of the unit, our refrigerators can now be serviced without being moved. Our innovative, front breathing feature also allows this model to be highly efficient in narrow spaces.
- Stainless steel cabinet construction**
 Super Deluxe (SD) models boast a stainless steel exterior (except galvanized steel back and bottom). SB models have an attractive wear-resistant black vinyl exterior. Heavy gauge stainless steel countertop and glide lids are perfect for sanitation and durability. The interior is stainless steel except galvanized steel top. Turbo Air Bottle Cooler model guarantees the utmost in cleanliness and long product life. It also adds a touch of style to the most refined setting.
- Rugged built-in removable bottle cap opener and cap catcher**
- Large capacity cooler cabinet requires only minimum floor space**
- Refrigerator holds 33°F ~ 38°F for the best in beverage preservation**



Model	Sliding Doors	CU./FT.	Capacity 12oz.btls. / 12oz.cans	# of Dividers	HP	AMPS	Crated Weight (lbs.)	L x D* x H† (inches)
TBC-80SD-N	3	22.6	30.8 / 43.2 Cases‡	5	1/3	2.5	378	80 1/2 x 26 1/2 x 33 1/4
TBC-80SB-N	3	22.6	30.8 / 43.2 Cases‡	5	1/3	2.5	378	80 1/2 x 26 1/2 x 33 1/4

Model : TBC-80SD/SB-N

ELECTRICAL DATA	
Voltage	115/60/1
Plug Type	ⓘ NEMA 5-15P
Full Load Amperes	2.5
Compressor HP	1/3
Refrigerant	R-290
Cord Length (ft.)	8.5
DIMENSIONAL DATA	
Capacity (12oz.btls./12oz.cans)‡	30.8 Cases / 43.2 Cases
Net Capacity (cu. ft.)	22.6
Ext. Length Overall (in.)	80 1/2 (2044mm)
Ext. Depth Overall (in.)*	26 1/2 (673mm)
Ext. Height Overall (in.)†	33 1/4 (845mm)
# of Dividers	5
# of Casters	 7EA
Net Weight (lbs.)	345
Gross Weight (lbs.)	378

Design and specifications subject to change without notice.

Actual shipping weight may differ due to extra packing materials for product protection.

* Depth does not include 2" for cap catcher or 2" for rear spacers.

† Height does not include 5" for caster height.

‡ Case capacity refers to 24 pack.

■ WARRANTY : 3 Year Parts and Labor Warranty Additional 2 Year Warranty on Compressor

■ STANDARD FEATURES

- *Anti-corrosion coated evaporator*
- *Self-contained system*
- *Standard 4" dia. swivel casters with locks on the front set*

■ OPTIONAL ACCESSORIES

- 1" caster, 1/2" diameter & 13 TPI: S28R813660 (non-brake)
- 2" caster for underbar series, 1/2" diameter: P0165B0100 (non-brake), P0165B0110 (w/ brake)
- 2.5" caster: 30265H0100 (non-brake), 30265H0200 (w/ brake)
- 5" caster, 1/2" diameter & 13 TPI: M726500100 (non-brake), M726500200 (w/ brake)
- Leveling leg, 1/2" - 13 TPI x 1.54": LFM1213566
- 6" adjustable stainless steel leg: P0121P0100

PLAN VIEW

(unit : inch)

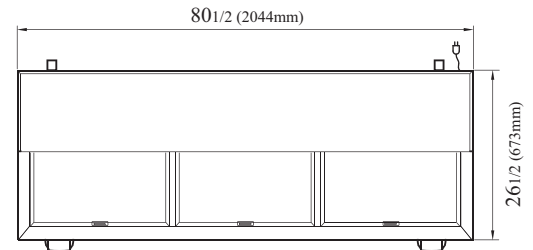

PLAN VIEW

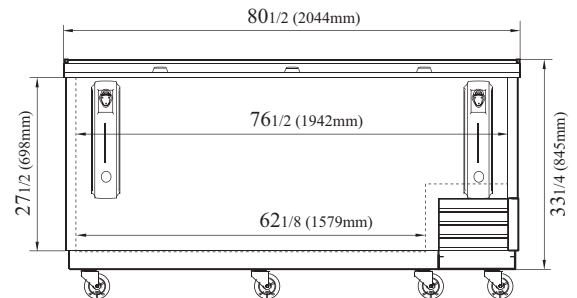

FRONT VIEW

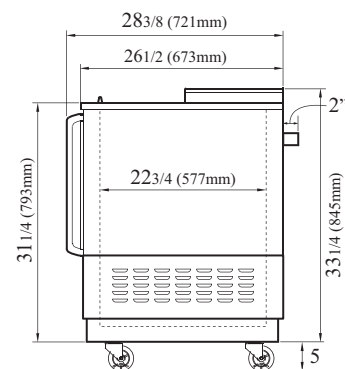

SIDE VIEW

Ver.20190812



- Turbo Air : 800-627-0032
- GK : 800-500-3519
- Warranty : 800-381-7770
- AC : 888-900-1002