

**Economical Size and Design**



**TGF-9F**



**TSD-27CF**



**TSD-35CF**



**TGF-13F**



**TSD-47CF**



**TSD-60CF**

**FEATURES / BENEFITS**

- **EFFICIENT REFRIGERATION SYSTEM**  
 Turbo Air's freezers are designed with oversized and balanced (CFC Free R-404A) refrigeration systems. These include efficient evaporators and condensers for faster freezing and greater efficiency.
- **LOW EMISSIVITY GLASS**  
 No condensation on the glass.  
 Reduces outer heat gain.  
 Low energy consumption.
- **DESIGNED FOR CONVENIENT ACCESS, FAST SERVICE, ATTRACTIVE CURVED GLASS LIDS**
- **HIGH-DENSITY POLYURETHANE INSULATION**  
 The entire cabinet structure are formed-in-place using high density, CFC free polyurethane insulation.
- **BOTTOM MOUNT COMPRESSOR UNITS**  
 Turbo Air's bottom mount compressor allows easier access for service and extra storage space above. In addition, the lower area provides a cooler and less greasy operating environment which results in reduced compressor running time.
- **FREEZER HOLDS - 9°F ~ 11°F FOR THE BEST IN FROZEN FOOD PRESERVATION**

Distributed By:  
 Commercial Refrigeration Service, Inc.  
<http://WWW.IceCubes.NET>  
 623-869-8881 or toll free 866-IceMakers

Model	Sliding Door	CU./FT.	Basket	HP	AMPS	Crated Weight	L D H
TGF-9F	1	85	-	1/4	44	198	44 2/7 x 27 2/5 x 39 2/5
TGF-13F	2	133	-	1/3	60	243	61 1/9 x 27 2/5 x 39 2/5
TSD-27CF	2	49	2	1/5	20	110	27 2/5 x 23 2/5 x 35 4/5
TSD-35CF	2	73	2	1/4	25	132	35 1/5 x 23 2/5 x 35 4/5
TSD-47CF	2	105	3	1/3	35	161	47 4/5 x 23 3/5 x 35 4/5
TSD-60CF	2	112	3	1/3	35	165	51 x 23 3/5 x 35 4/5

MODEL	TGF-9F	TGF-13F
Exterior Dimension	44 <sup>2/7</sup> X27 <sup>2/5</sup> X39 <sup>2/5</sup>	61 <sup>1/9</sup> X27 <sup>2/5</sup> X39 <sup>2/5</sup>
Voltage (i) NEMA-5-15P	Ⓜ115V/60Hz	Ⓜ115V/60Hz
Amp	4.4 A	6 A
Compressor (HP)	1/4	1/3
Sliding Doors	1EA	2EA
Net Weight	185lbs	253lbs
Cubic Feet	8.5	13.3
Cord Length	8.2 ft.	8.2 ft.
Plug-In	NEMA 5-15P	NEMA 5-15P

- SELF-CONTAINED SYSTEM
- 2.5" CASTERS STANDARD
- HEAVY DUTY, WHITE PE (POLYETHYLENE) DIVIDERS INCLUDED

\*Design and specifications subject to change without notice.

- **WARRANTY :** 1 Year Labor and Parts Warranty  
 Additional 4 Years Warranty on Compressor

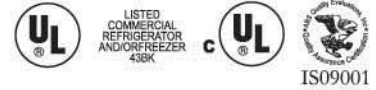

(unit : inch)

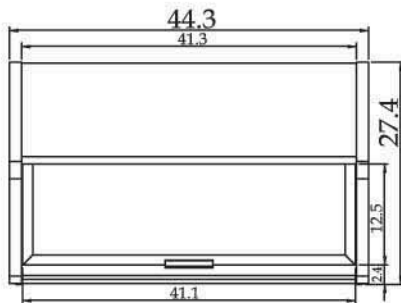

TGF-9F PLAN VIEW

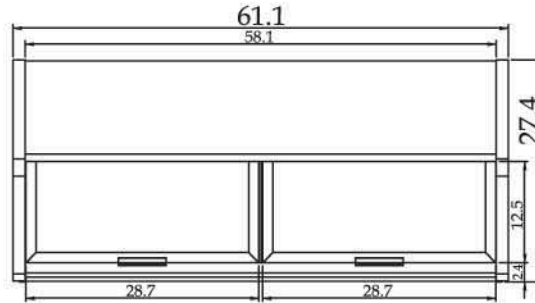

TGF-13F-PLAN VIEW

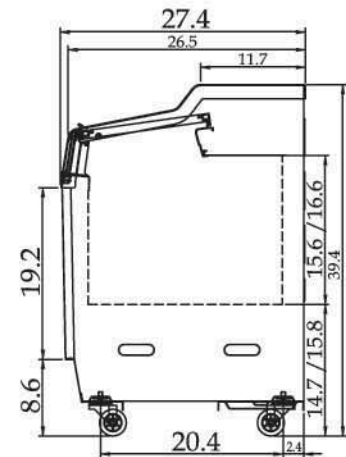

SIDE VIEW

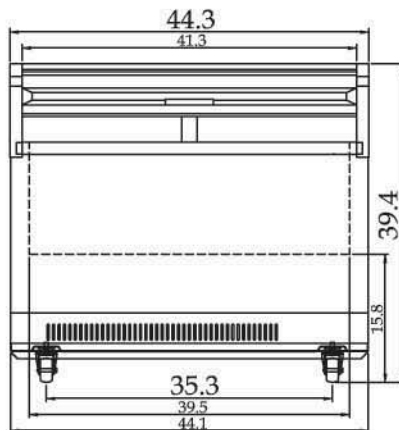

TGF-9F FRONT VIEW

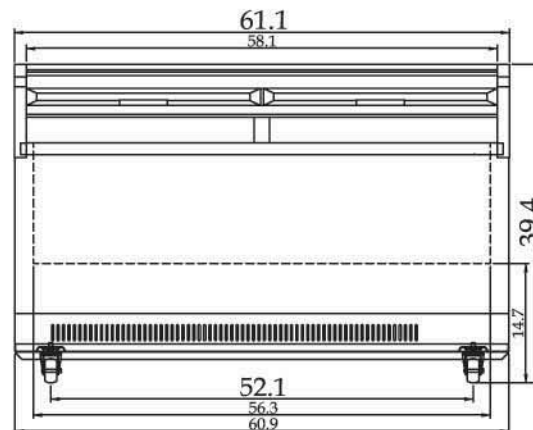

TGF-13F-FRONT VIEW

**TSD-27CF / TSD-35CF / TSD-47CF / TSD-60CF SPECIFICATIONS**

MODEL	TSD-27CF	TSD-35CF	TSD-47CF	TSD-60CF
Exterior Dimension (LxDxH)	27 <sup>2</sup> / <sub>5</sub> X23 <sup>2</sup> / <sub>5</sub> X35 <sup>4</sup> / <sub>5</sub>	35 <sup>1</sup> / <sub>5</sub> X23 <sup>2</sup> / <sub>5</sub> X35 <sup>4</sup> / <sub>5</sub>	47 <sup>4</sup> / <sub>5</sub> X23 <sup>3</sup> / <sub>5</sub> X35 <sup>4</sup> / <sub>5</sub>	51X23 <sup>3</sup> / <sub>5</sub> X35 <sup>4</sup> / <sub>5</sub>
Interior Dimension (LxDxH)	22 <sup>1</sup> / <sub>3</sub> X18 <sup>2</sup> / <sub>5</sub> X20 <sup>8</sup> / <sub>9</sub>	30 <sup>1</sup> / <sub>5</sub> X18 <sup>2</sup> / <sub>5</sub> X27 <sup>1</sup> / <sub>2</sub>	42 <sup>1</sup> / <sub>5</sub> X17 <sup>4</sup> / <sub>5</sub> X25 <sup>3</sup> / <sub>5</sub>	45 <sup>2</sup> / <sub>7</sub> X17 <sup>4</sup> / <sub>5</sub> X25 <sup>3</sup> / <sub>5</sub>
Voltage (Ⓢ) NEMA-5-15P	Ⓢ115V/60Hz	Ⓢ115V/60Hz	Ⓢ115V/60Hz	Ⓢ115V/60Hz
Amp	2.0 A	2.5 A	3.5 A	3.5 A
Compressor (HP)	1/5	1/4	1/3	1/3
Sliding Doors	2EA	2EA	2EA	2EA
Weight	99lbs	121lbs	136lbs	141lbs
Cubic Feet	4.9	7.3	10.5	11.2
Cord Length	6.6 ft.	6.6 ft.	6.6 ft.	6.6 ft.
Plug-In	NEMA 5-15P	NEMA 5-15P	NEMA 5-15P	NEMA 5-15P
Baskets	2EA	2EA	3EA	3EA
Net Capacity	36.5 Gal	55.0 Gal	78.7 Gal	84.0 Gal

\*Design and specifications subject to change without notice.

■ **WARRANTY :** 1 Year Labor and Parts Warranty  
 Additional 4 Years Warranty on Compressor

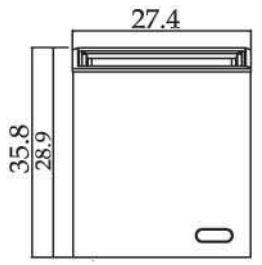

TSD-27CF FRONT VIEW

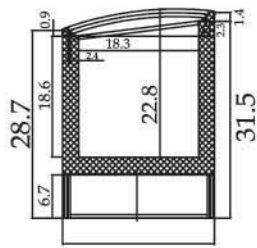

TSD-27CF SIDE VIEW

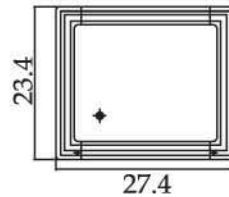

TSD-27CF PLAN VIEW

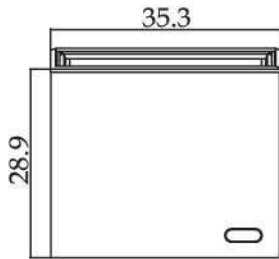

TSD-35CF FRONT VIEW

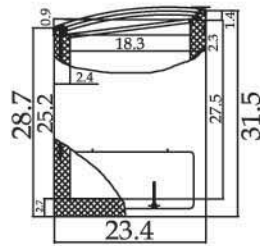

TSD-35CF SIDE VIEW

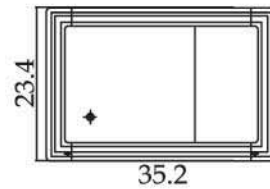

TSD-35CF PLAN VIEW



TSD-47CF FRONT VIEW

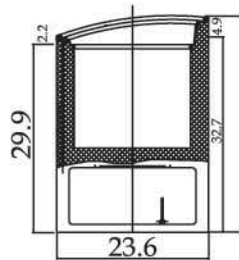

TSD-47CF/TSD-60CF SIDE VIEW

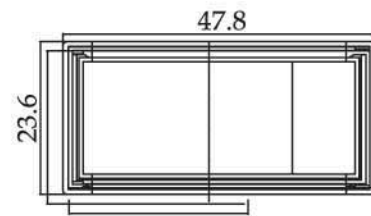

TSD-47CF PLAN VIEW

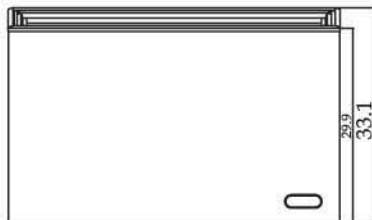

TSD-60CF FRONT VIEW

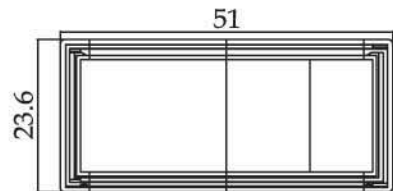

TSD-60CF PLAN VIEW

(unit : inch)