

**REFRIGERATOR MANUFACTURER**  
**Turbo air**  
 more durable, efficient, beautiful

4184 E. Conant St.  
 Long Beach, CA 90808  
 Tel. 310-900-1000  
 Fax. 310-900-1077  
[www.turboairinc.com](http://www.turboairinc.com)

Project :	
Model # :	
Item # :	Qty :
Available W/H :	
Approval :	

## Milk Coolers - Dual Sided Door

Milk Coolers  
 Super Deluxe Series

### Patented Self-Cleaning Condenser



This product is equipped with a fine mesh filter to the front of the condenser to catch dust, and a rotating brush that moves up and down daily to remove excess buildup outward and away.

**Model : TMKC-58D-N-WA**  
**TMKC-58D-N-WS**  
**TMKC-58D-N-SA**  
**TMKC-58D-N-SS**



### ≡ FEATURES & BENEFITS ≡

■ **Maintenance-free, Self-Cleaning Condenser (patented) Only at Turbo Air**

The accumulation of dust in the condenser causes the failure or breakdown of refrigerators. Refrigerators run normally until they reach a certain level of accumulation. At some point, when they are over the limit, their performance drops quickly resulting in damage to, or disposal of the stored products in refrigerators. The self-cleaning condenser device keeps the condenser clean and prevents system failure by automatically brushing daily.

■ **Hydrocarbon Refrigerants (R-290)**

With innovative and eco-friendly technology, Turbo Air brings you hydrocarbon refrigerators designed to meet the new standards of EPA and DOE in 2017. Hydrocarbon refrigerants do not deplete the ozone layer and have very low contribution to the global warming (ODP-0, GWP-3).

■ **Exterior digital thermometer standard**

Exterior digital temperature display allows easy reading, precise, and constant temperature. This level of precision allows milk to remain fresh and safe over an extended period of time.

■ **Sturdy and clean, durable cabinet construction**

Exterior is stainless steel or white coated steel with stainless steel door. Interior is comprised of stainless steel.

■ **High-density polyurethane insulation**

The entire cabinet construction is foamed-in-place using high density, environmental friendly CFC free polyurethane insulation.

■ **Convenient bottom floor drain standard with hose adapter**

Floor drain is located in the rear on the right hand side for easy clean out. The hose adapter allows for convenient connecting to drain hose.

■ **Stainless steel self-service doors have drop front feature and hold-open flip-up top lid**

■ **4" dia. swivel casters standard for easy movement, two with brakes to lock the unit in place**

■ **Refrigerator holds 33°F ~ 38°F for the best in milk preservation**



Model	# of Doors	# of Floor Rack	CU./FT.	Crate Capacity (13 x 13 x 11)	HP	AMPS	Crated Weight (lbs.)	L x D x H <sup>†</sup> (inches)
TMKC-58D-N-**	4	3	24.5	16	1/4	7.0	376~403	58 x 32 <sup>7</sup> / <sub>8</sub> x 41 <sup>5</sup> / <sub>8</sub>

## Model : TMKC-58D-N-\*\*

SPECIFICATIONS	
Voltage	115/60/1
Plug Type	Ⓢ NEMA 5-15P
Full Load Amperes	7.0
Compressor HP	1/4
Cord Length (ft.)	9
Refrigerant	R-290
Net Capacity (cu. ft.)	24.5
Ext. Length (in.)	58 (1475mm)
Ext. Depth (in.) *	32 7/8 (836mm)
Ext. Height (in.) †	41 5/8 (1056mm)
# of Doors	4
Gross Weight (lbs.)	376~403
Crate Capacity (13"x13"x11")	16

Design and specifications subject to change without notice.

Actual shipping weight may differ due to extra packing materials for product protection.

\* Depth does not include 1-1/8" (30mm) for bumpers.

† Height does not include 5" (127mm) for caster height.

- **WARRANTY : 3 Year Parts and Labor Warranty**  
**Additional 2 Year Warranty on Compressor**

\*\* Product number

Model	Gross Weight (lbs.)	EXTERIOR	INTERIOR
TMKC-58D-N-WA	383	White Vinyl & Stainless Steel	Aluminum
TMKC-58D-N-WS	403	White Vinyl & Stainless Steel	Stainless Steel
TMKC-58D-N-SA	376	Stainless Steel	Aluminum
TMKC-58D-N-SS	396	Stainless Steel	Stainless Steel

- **Door lock standard**
- **Heavy duty floor racks standard**
- **Door support bumpers standard**
- **Self-contained system**
- **Corner bumpers available (optional)**

### OPTIONAL ACCESSORIES :

- Corner bumpers (4pcs/set): K345201160

## PLAN VIEW

(unit : inch)

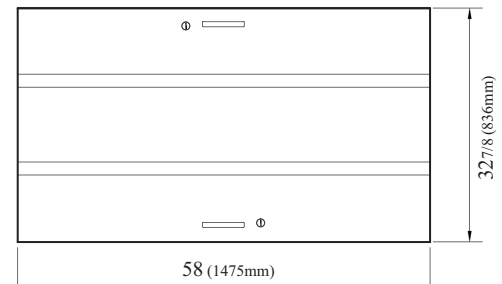

PLAN VIEW

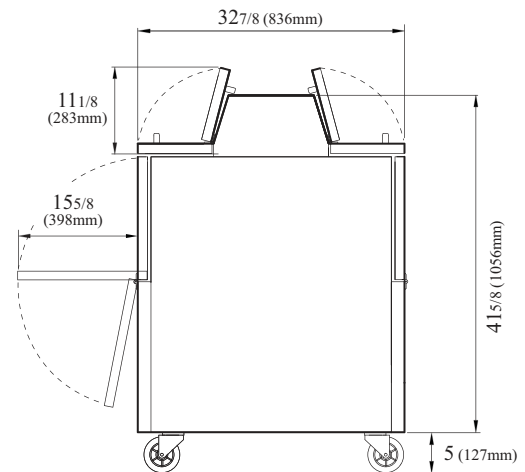

SIDE VIEW

Ver.201703

NATURAL Refrigerant



- Turbo Air : 800-627-0032
- GK : 800-500-3519
- Warranty : 800-381-7770
- AC : 888-900-1002

Turbo air REFRIGERATOR MANUFACTURER

GERMAN KNIFE

RADIANCE

GREEN WORLD

Turbo air AIR CONDITIONER MANUFACTURER