



HOT-N CRISPY™ FRY WARMER

Model UW-17

Innovative Fry Warmer keeps fried foods hot and crispy on the outside and moist and delicious inside. The convected air heating technology doubles the holding time of fries, chicken tenders, appetizers and more without drying or creating a tough texture or a limp product.

Parts are easy to remove for cleaning and are built out of durable stainless steel. The UW-17 includes an automatic safety cut-off feature to prevent overheating.



FEATURES AT A GLANCE

- Overheat safety system
- Pan Divider
- Safety Cut-Off
- Removable parts for easy cleaning
- Up to 8 lb holding capacity
- 100% hand built-in the U.S.A.



ELECTRIC OPERATION

Energy efficiency and easy installation are a perfect pairing for your food service operation.



CONVECTED AIR HEAT

Convected air heat keeps fried foods crispy on the outside and moist inside.



www.bkideas.com

42 Allen Martin Drive, Essex Junction, VT 05452 • Phone: (802) 658-6600 • Fax: (802) 864-0183

BK1296 Rev A (1/21)

EQUIPMENT DIMENSIONS

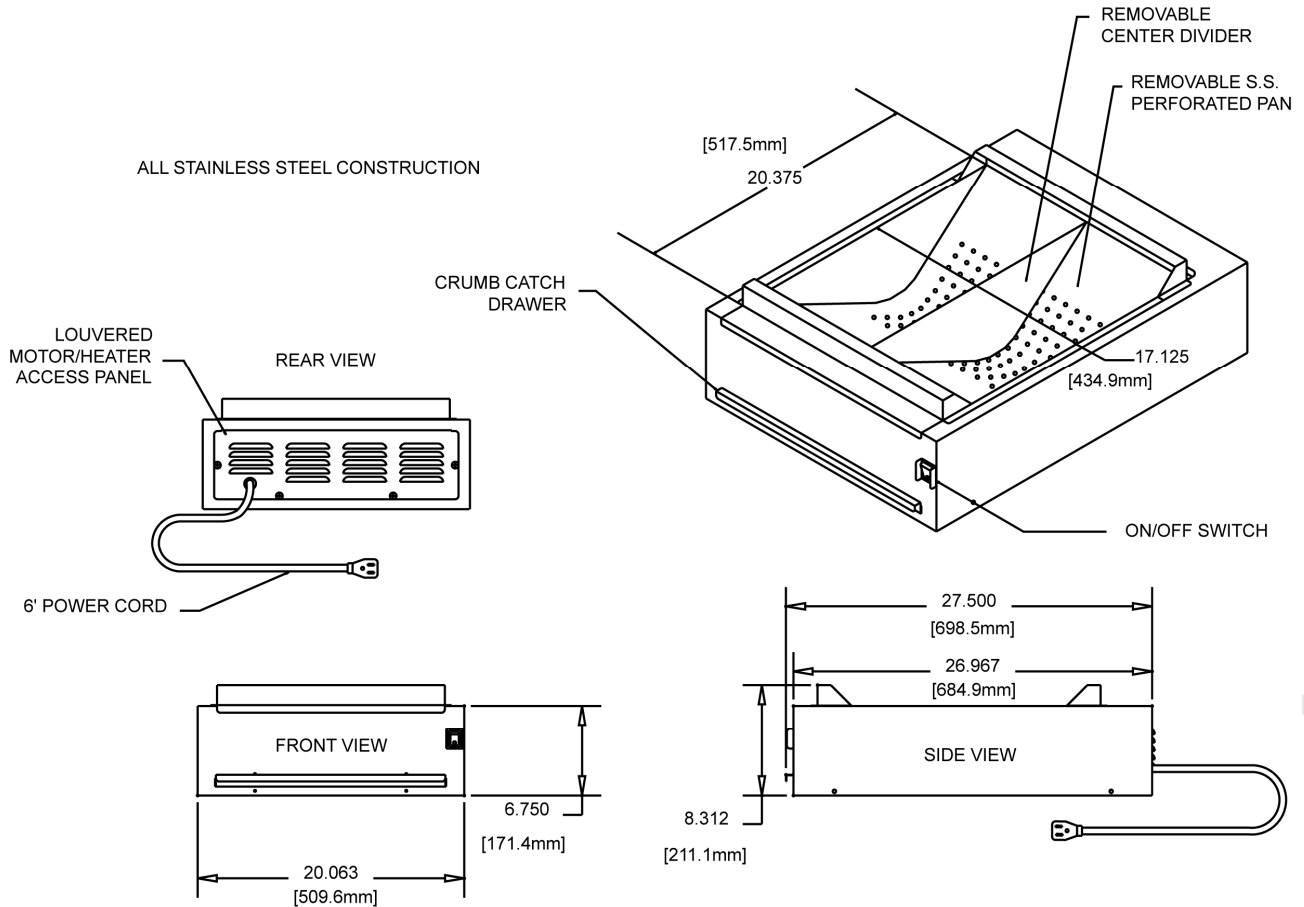

MECHANICAL SPECIFICATIONS

Dimensions	Uncrated	Crated
Height	8.3 in (211mm)	9 in (228mm)
Width	20 in (509.6mm)	21 in (533mm)
Depth	27.5 in (698.5mm)	28.5 in (724mm)
Floor space	3.82 sq ft (0.355m ²)	3.12 ft 3(.088 M3)
Weight	70 lb. (31.75 kg.)	75 lb. (34.02 kg.)

ELECTRICAL OPTIONS

Volts	Amps	Breaker	kW	Wires	Phase
120	8.3	15	1	2	1
220	4.5	15	1	2	1



Visit www.bkideas.com to view all accessories available with this model.