



BEVERAGE-AIR

| | |
|-----------------|------|
| Project: _____ | AIA# |
| Item: _____ | |
| Location: _____ | SIS# |
| Approved: _____ | |

WTRCS36HC CHEF BASE REFRIGERATOR

CHEF BASE REFRIGERATOR

WTRCS36HC Two Drawer Chef Base Hydrocarbon Series

MODEL:
WTRCS36HC



3 Year Parts/Labor Warranty
Additional 4 Year Compressor Warranty

CABINET CONSTRUCTION

- Stainless steel front, sides, drawers and grille (galvanized back & bottom)
- Interior liner is made of corrosion resistant aluminum
- Top has full marine edge to prevent spills from dripping over sides
- Full electronic control
- Top weight capacity 1000 lbs
- One-piece, snap-in magnetic drawer gasket
- 12-Gauge stainless steel drawer slides with Delrin® rollers rated at 275 lbs
- Lifetime warranty on all drawers and slides
- Heavy duty, fire-proof, reinforced insulated 16 gauge top
- No heat shield required (must adhere to proper clearance per owners manual)
- Accommodates 6" deep full size food service pans (not included)
- Self-closing drawer feature
- Compressor available on left or right, specify at time of unit order
- 3" Casters, 2 with brakes standard

OPTIONS & ACCESSORIES

- Stainless steel back
- Stainless steel interior
- Additional pan supports
- 6" Adjustable legs, 6" seismic legs
- 6" Casters
- Gasket guards
- Flat top overhang
(up to 6" overhang on each side)
- Remote option*
(refrigerant must be specified at time of order, see note on back on page)

REFRIGERATION SYSTEM

- Uses environmentally friendly, energy efficient R290 refrigerant, and meets all regulatory requirements for CARB, SNAP, DOE & more
- Adaptive defrost
- Non-electric defrost with hot gas condensate evaporation
- Refrigerator capable of maintaining product temperature 36°F to 38°F



Please verify qualifying units by visiting:
www.energystar.gov/cfs

3779 Champion Blvd., Winston-Salem, NC 27105
1-888-845-9800 Fax: 1-336-245-6453
Beverage-Air.com Sales@bevair.com



BEVERAGE-AIR

| MODEL | WTRCS36HC |
|--------------------------------------|------------------|
| EXTERNAL DIMENSIONAL DATA | |
| Width Overall | 36" |
| Depth Overall (with handle & bumper) | 34 3/4" |
| Height Overall (with casters) | 24 3/8" |
| No. of Drawers | 2 |
| Depth with Drawers Extended | 61 3/4" |
| Drawer Openings | 22 1/2" x 6 1/2" |
| INTERNAL DIMENSIONAL DATA | |
| NET Capacity (cubic ft.) | 5.64 |
| Internal Width Overall (in) | 22 7/8" |
| Internal Depth Overall (in) | 26" |
| Internal Height Overall (in) | 16 3/8" |
| ELECTRICAL DATA | |
| Full Load Amperes | 1.7 |
| REFRIGERATION DATA | |
| Horsepower | 1/6 |
| Capacity (BTU/Hr) | 1110 |
| Heat Rejection (BTU/Hr) | 1665 |
| Charge (lbs/grams) | 0.265/120 |
| WEIGHT DATA | |
| Gross Weight - Crated | 350 lbs |
| Height - Crated | 27" |
| Width - Crated | 40" |
| Depth - Crated | 38" |

*NOTE: Remote units are field wired and come with 6" legs. Refrigerant must be specified at time of order.

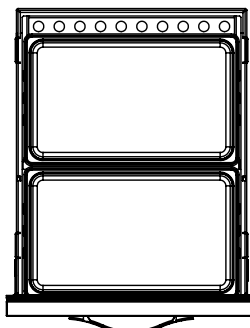

(Per drawer)

Chef Base Refrigerator Model: WTRCS36HC

Model Views

Required Clearance: Rear 1"

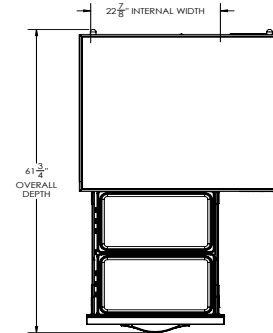

PLAN VIEW

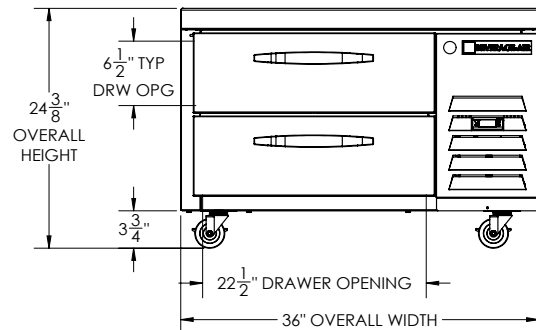

ELEVATION VIEW

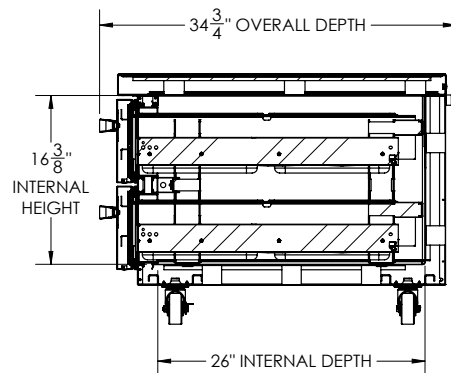

SIDE VIEW

ELECTRICAL CONNECTION



115/60/1
NEMA 5-15P

Unit pre-wired at factory and include 8' long cord and plug set.



3779 Champion Blvd., Winston-Salem, NC 27105 1-888-845-9800 Fax: 1-336-245-6453 Beverage-Air.com Sales@bevoir.com

an Ali Group Company



The Spirit of Excellence